



BLUELIFT
PIATTAFORME AEREE



C21/11
200 kg

TRUCKED AERIAL WORK PLATFORM

NECELLE ÉLEVATRICE CHENILLÉE

RAUPEN-ARBEITSBÜHNE

PLATAFORMA DE ORUGA PARA LO TRABAJO EN ALTURA

BLUEAARIA

PIATTAFORMA AEREA CINGOLATA

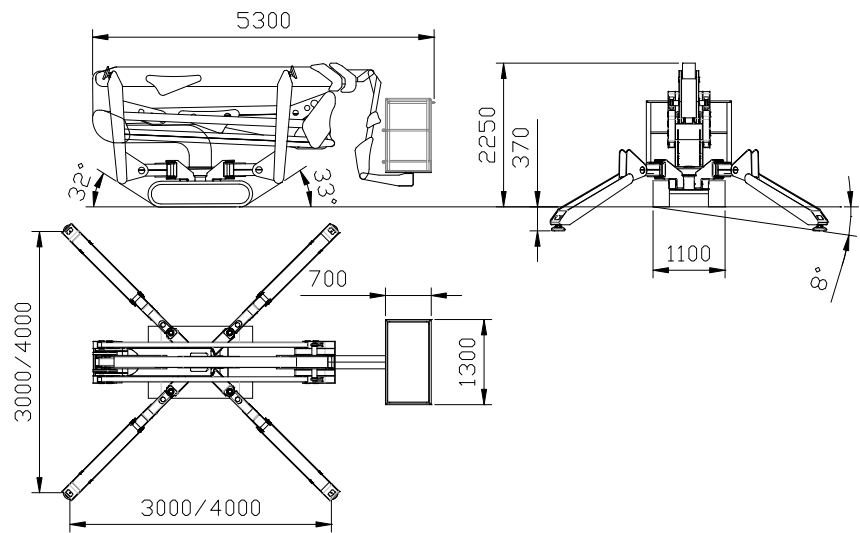
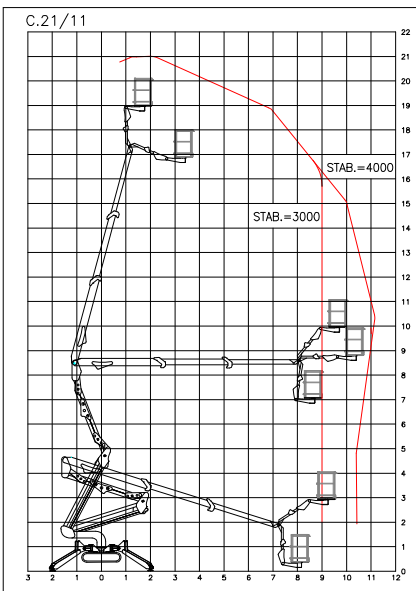

The reported informations are indicative and not binding; Blue lift reserve the right to make possible changes at any time and without notice.

Optional: kg 250 winch, without removal of basket

SPECIFICATIONS C21/11

• PLATFORM	removable, aluminium, dim. 1300x 700 xh1100, rotation 45°x/45 °x
• PLATFORM LEVELLING	elettronic proportional controls
• BOOM	all steel
• BOOM ANGLE	0° +75°
• PANTOGRAPH II	double boom , all steel, -1°+68°
• PANTOGRAPH I	4 boom all steel, -2.5°/ +62.5°
• SLEWING TURRET	700° not continuous
• CONTROLS	proportional controls
• OIL TANK CAPACITY	40L
• DOUBLE PUMP	6L+6L
• CIRCUIT PRESSURE	180bar
• MAXIMUM GRADIENT	25%
• MAX WIND SPEED	12,5 m/sec
• ELECTRIC SYSTEM VOLTAGE	12V
• MAX MANUAL FORCE	40 daN
• CONTROL SPEED	0,4 m/sec
• LOAD CAPACITY	200 kg
• NO. OPERATORS	2
• MAX WORKING HEIGHT	21m
• MAX WORKING OUTREACH	11m
• MACHINE WEIGHT	3700Kg
• TRACTION	tracked with remote control
• MAX TRASLATION SPEED	1,5km/h
• ENGINE	diese HATZ
• OUTRIGGERS	collapsible , hidraulic descent

STANDARD SAFETY EQUIPMENTS

Priority of platform controls

Locks for the safety belts on the platform

Emergency push-button with engine stop

Hand pump for the emergency descent of the platform

Automatic opening of the brake when the rotation begins

Aerial stucture locking till the stabilistation is complete

A Protection with pressure relief valve on the hydraulic system

Overcentre lock valves on all the cylinders

Translation intermittent sound alarm

Automatic opening of the brake when traslation begins

Complete stabilisation waming lights

Hour-meter

Electro-hydraulic trasmission

220 V Supply with plug on the platform with earth leakage circuit breaker

Electric-pump 3,8l – 220 V

Gearcase protection cap

Produced according to EN 280 norm and international safety regulations

Use and maintenance handbook



BLUELIFT S.r.l.
Strada Provinciale n.18 "Conca", snc
Località Santa Maria del Piano
47854 Montescudo (RN) – ITALY
Tel. +39 0541 756872
Fax +39 0541 729800
www.bluelift.it
email: info@bluelift.it