

ARTICULATING BOOM

HA 20 PX



- +70 / -70° fly jib.
- 44 ft 3 in (13.5 m) horizontal outreach.
- Standard 4 wheel drive and 4 wheel steer.
- 550 lb (250 kg) platform capacity.
- 40% gradeability.

ISO 9001
GROUP
PINGUELY
HAULOTTE



ARTICULATED BOOMS



VERTICAL MASTS



TELESCOPIC BOOMS



SCISSOR LIFTS



TRAILERS

Haulotte®

ON THE UP

HA 20 PX

Articulating boom

The Haulotte® advantages

- Improved working area via a positive / negative articulating fly jib with 140° movement
- 12 ft 8 in (3.9 m) turning radius for improved manoeuvrability
- Hydraulic differential lock and 17 in (42 cm) ground clearance for improved rough terrain capability
- Continuous 360° turntable rotation
- 180° hydraulic platform rotation
- Compact travel / transport dimensions
- Full proportional controls and simultaneous boom functions improve productivity
- Work platform overload limiter increases safety
- 2.8 mph (4.5 km/h) travel speed
- Robust, reliable and easy to maintain design

STANDARD FEATURES

- 4 wheel drive and 4 wheel steer
- 5° tilt alarm
- Deutz air cooled diesel engine
- 220 V/16 A power line to platform
- 12 V proportional controls at platform
- Free wheeling device
- Battery electric emergency lowering system
- Safe use in winds up to 37 mph (60 km/h)
- Hourmeter
- Slewing block pin
- Towing hooks / lifting eyes
- 2 hooks for safety harness in platform

OPTIONS & ACCESSORIES

- Rotating beacon
- Flashing light
- Travel alarm
- Catalytic exhaust
- Hostile environment kit
- 2.3 x 0.8 / 7 ft 6 in x 2 ft 7 in large platform
- Sand tyres / Road tyres
- On-board 3.3 kW generator
- Encoded starting device
- Working light
- Hot countries kit / Cold countries kit



┌ D I S T R I B U T E D B Y ┐

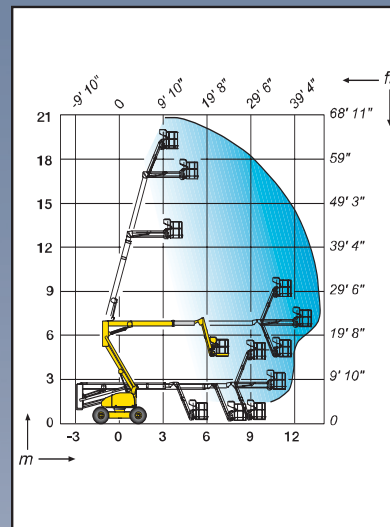
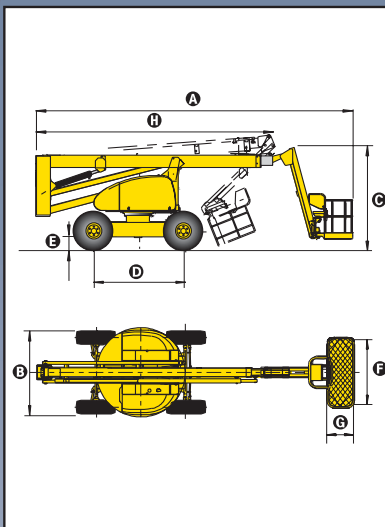

SPECIFICATIONS

Working height	68 ft	20.65 m
Platform height	61 ft	18.65 m
Horizontal outreach	46 ft	14 m
Up & over clearance	22 ft 3 in	6.8 m
Platform capacity	550 lb	250 kg
Fly jib range of motion	140° (+70°/-70°)	140° (+70°/-70°)
A Stowed length	29 ft 6 in	9.0 m
B Width	7 ft 10 in	2.38 m
C Stowed height	8 ft 9 in	2.67 m
D Wheelbase	9 ft 2 in	2.8 m
E Ground clearance	17 in	42 cm
F x G Platform size	71 in x 32 in	1.8 m x 0.8 m
H Travel/transport length	22 ft 7 in	6.9 m
Tailswing	0	0
Drive speed	0.8 mph - 2.8 mph	1.2 km/h - 4.5 km/h
Outside turning radius	12 ft 8 in	3.9 m
Turntable rotation (continuous)	360°	360°
Hydraulic platform rotation	180°	180°
Gradeability	40%	40%
Engine	Diesel Deutz 52 hp - 38 kw	
Controls	proportional	proportional
Tyres (foam filled)	15 R 22	15 R 22
Hydraulic tank	33 gallons	150 l
Fuel tank	33 gallons	150 l
Weight	27.027 lb	12.260 kg



Haulotte®

HAULOTTE UK LTD • Stafford Park 6 - Telford - Shropshire TF3 3AT - UK • Tel : +44 (0)1952 292753 • Fax : +44 (0)1952 292758 • e-mail: haulotte@haulotte.co.uk
 HAULOTTE SCANDINAVIA AB • Aröds Industriväg 66B - 44243 Hisingsbacka - SWEDEN • Tel : +46 (0) 31 744 32 90 • Fax : +46 (0) 31 744 32 99 • e-mail: hwallin@haulotte.se
 HAULOTTE AUSTRALIA PTY LTD • 39 Nicholas Drive - Dandenong - VIC - 3175 - AUSTRALIA • Tel : +61 (0)3 9706 6787 • Fax : +61 (0)3 9706 6797 • e-mail: sales@haulotte.com.au
 PINGUELY-HAULOTTE GROUP • La Péronnière - B.P. 9 - 42152 L'Horme - FRANCE • Tél : +33 (0) 4 77 29 24 24 • Fax : +33 (0) 4 77 29 43 95 • e-mail: haulotte@haulotte.com
 Web : <http://www.haulotte.com>