

DLX15

1 Slewing base

2 Basket

3 Chassis

4 Layout slewing base

5 Layout basket

6 Layout chassis

7 Layout lift

8 Info

9 Partslist

10 Generator

CONTROL BOX SLEWING BASE

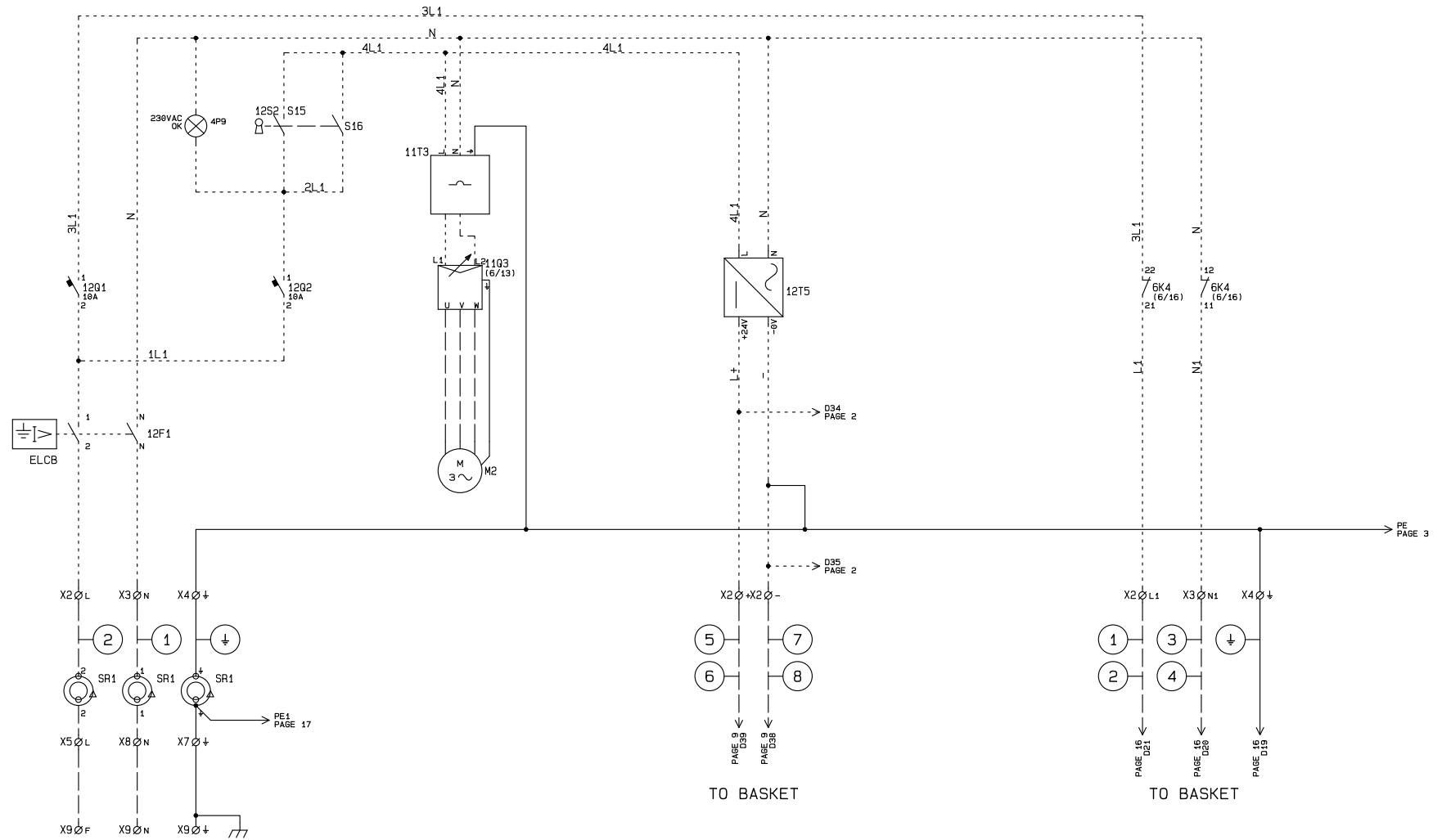

DENKA LIFT

Lift type : DLX15	No : 13131	Hydraulics : -	Dia. No. : -
Extra equipment: -			Title : Slewing base
Drawn by : CTJ	Approved by : CTJ	Date : 03.11.06 Rev. : -	Page : 1 of 32

CONTROL BOX SLEWING BASE

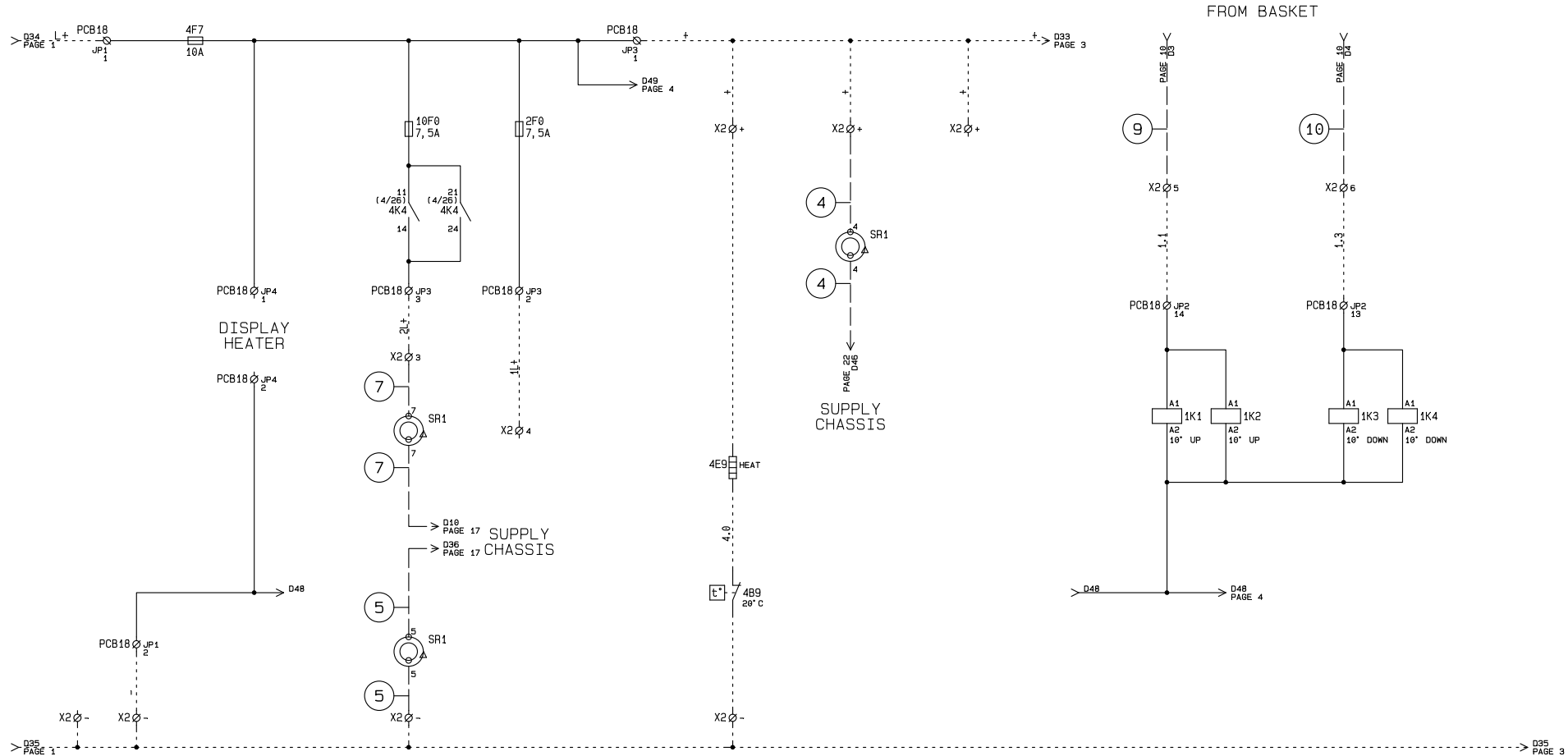

CONTROL BOX SLEWING BASE

7700

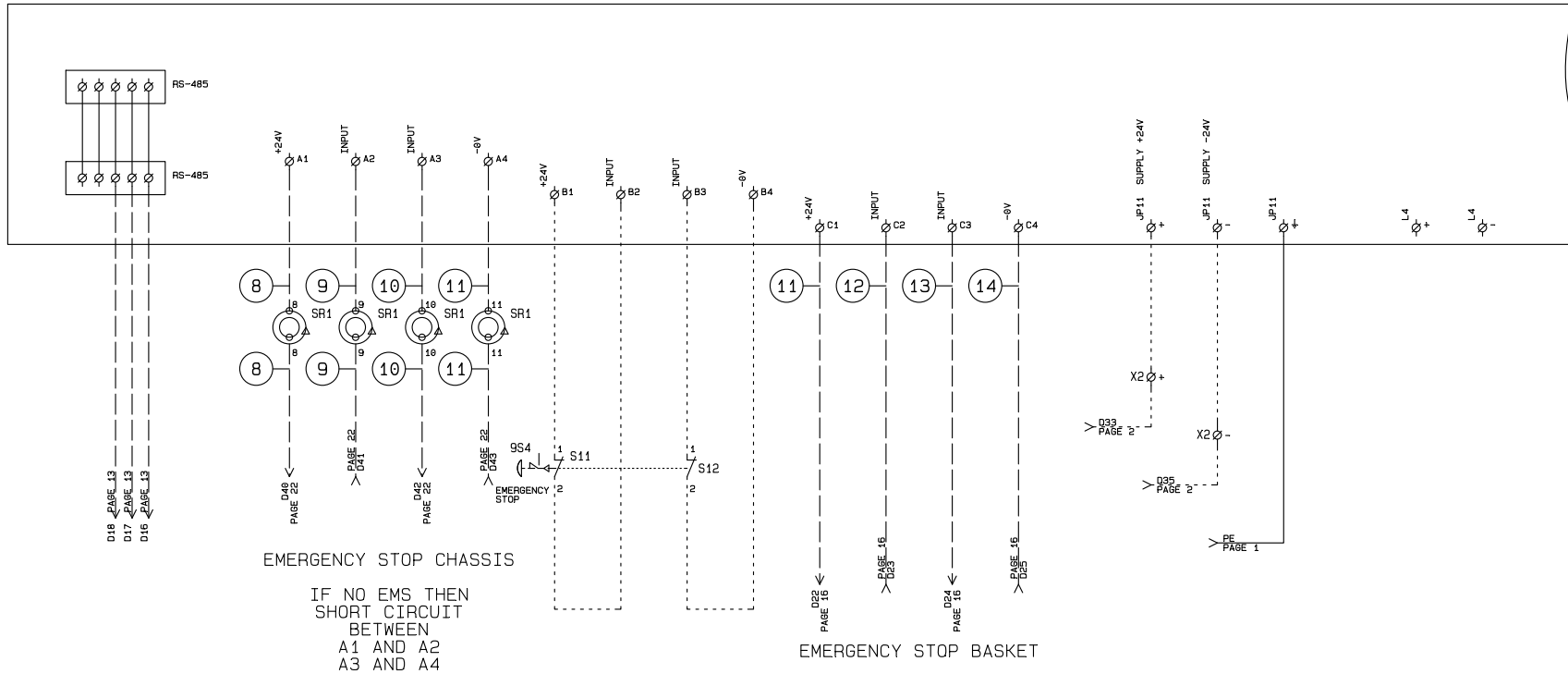

CONTROL BOX SLEWING BASE

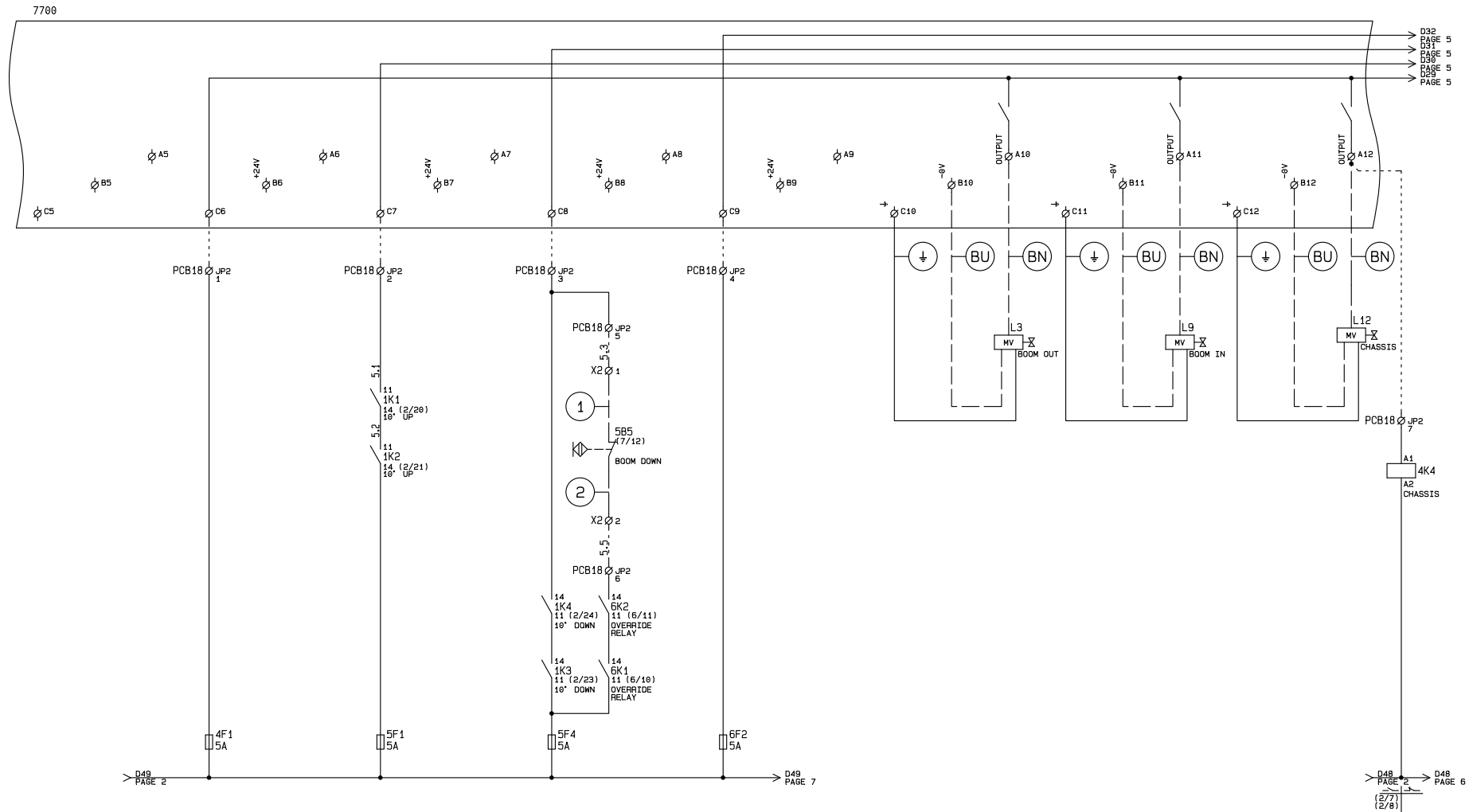

DENKA LIFT

Lift type : DLX15

No : 13131

Hydraulics : -

Dia. No. : -

Extra equipment: -

Title : Slew base

Højvang 5 4300 Holbæk Phone 59 45 55 00

Drawn by : CTJ

Approved by : CTJ

Date : 03.11.06 Rev. : -

Page : 4 of 32

CONTROL BOX SLEWING BASE

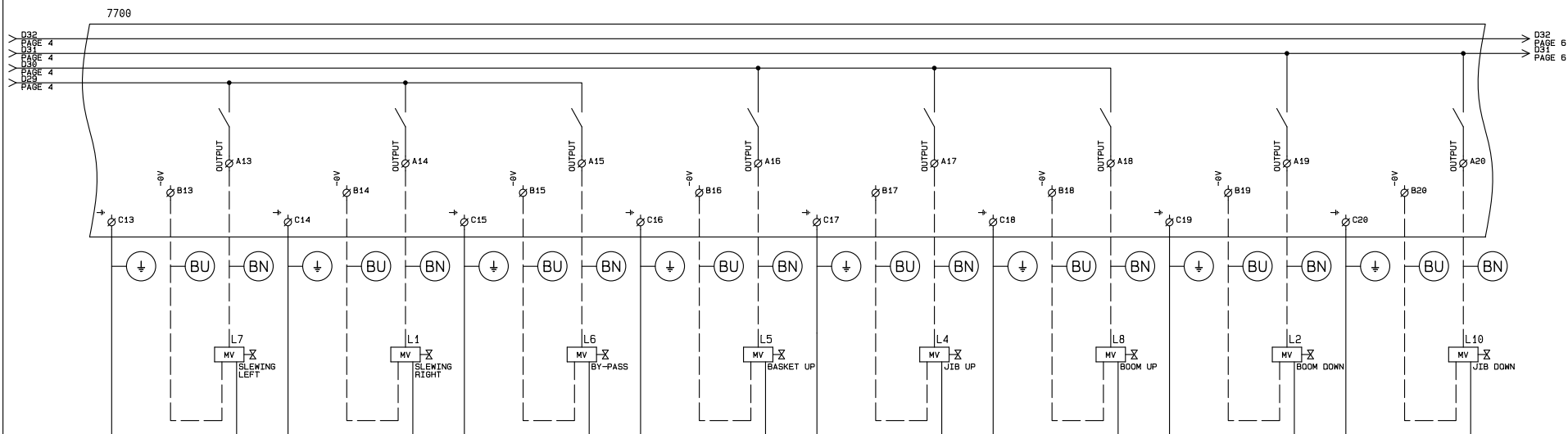

CONTROL BOX SLEWING BASE

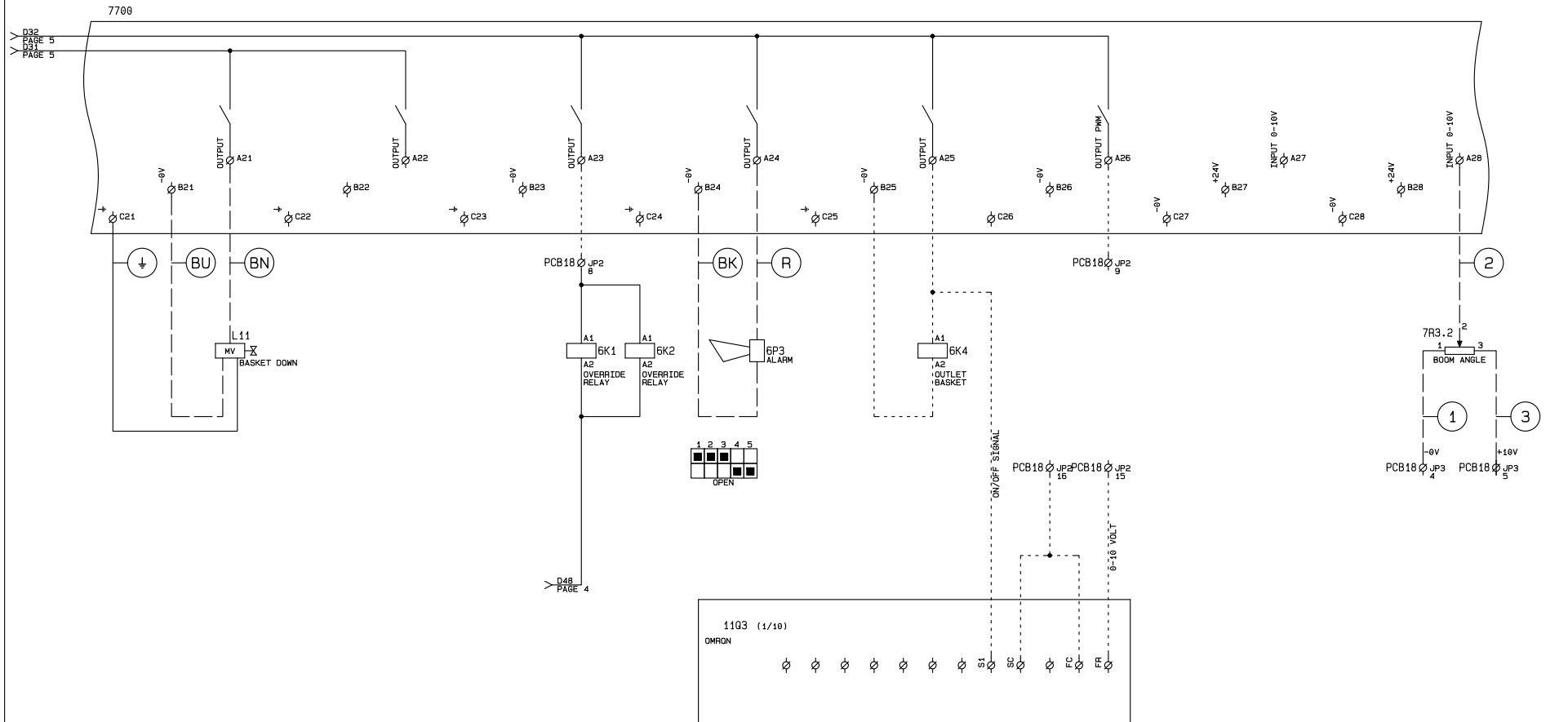

CONTROL BOX SLEWING BASE

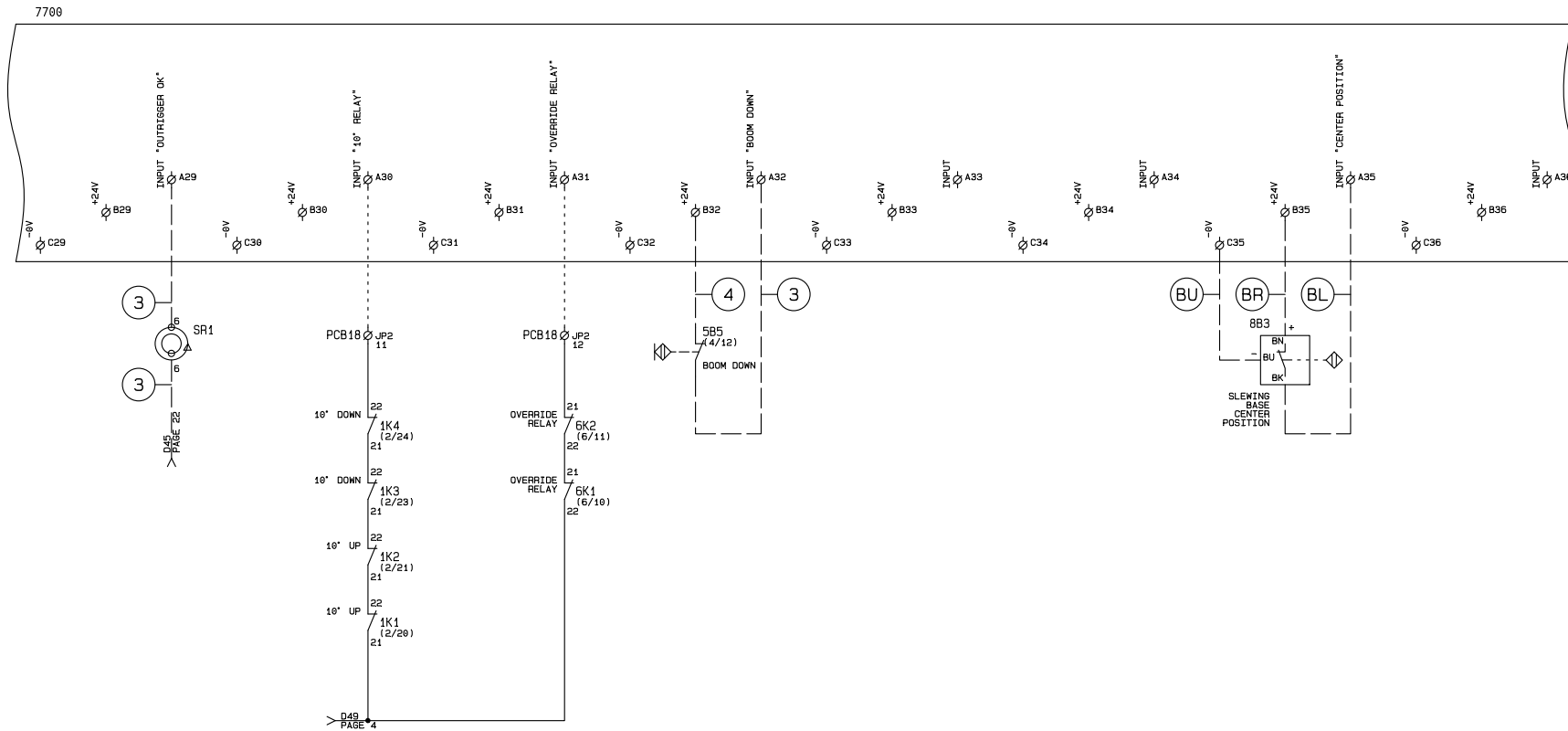

CONTROL BOX SLEWING BASE

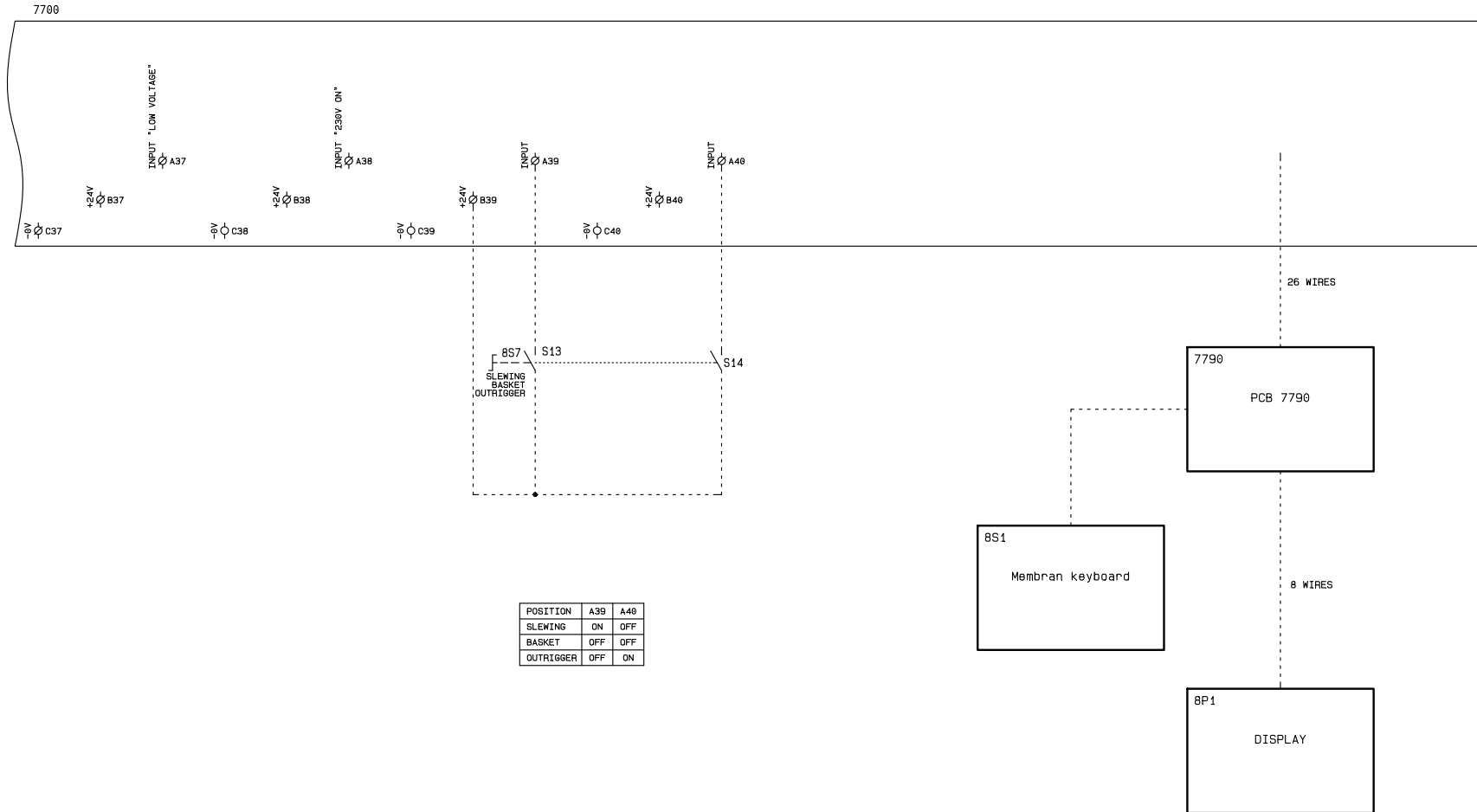

CONTROL BOX BASKET

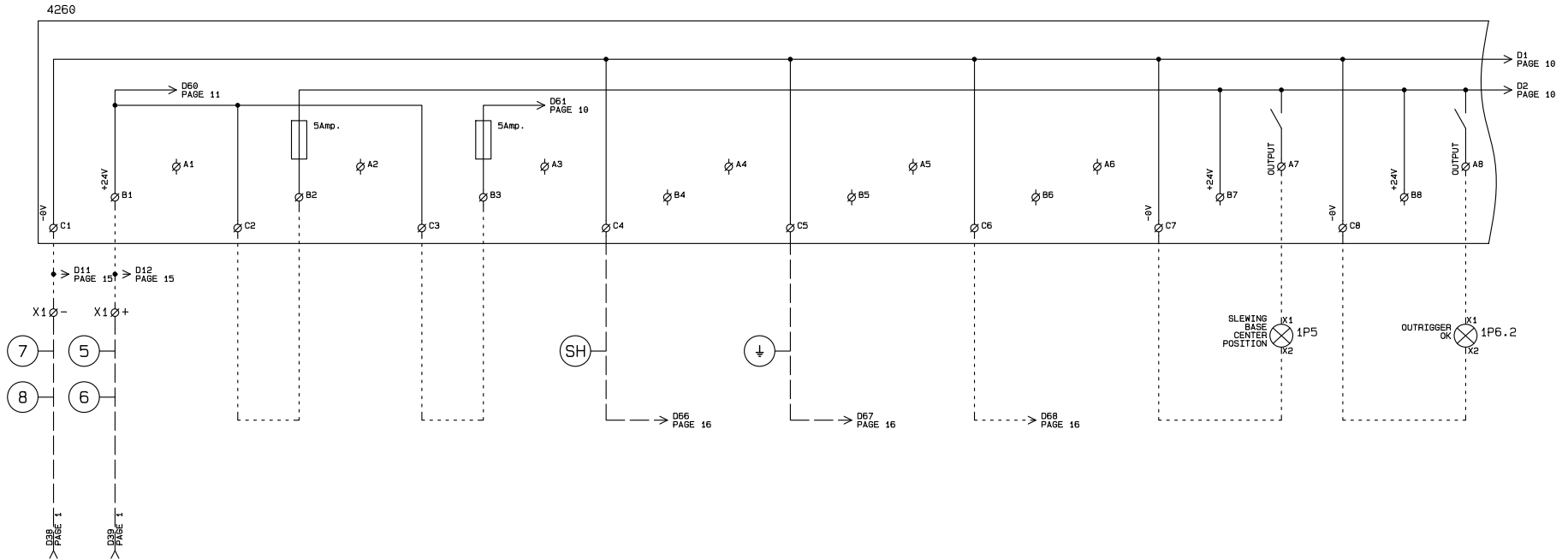

CONTROL BOX BASKET

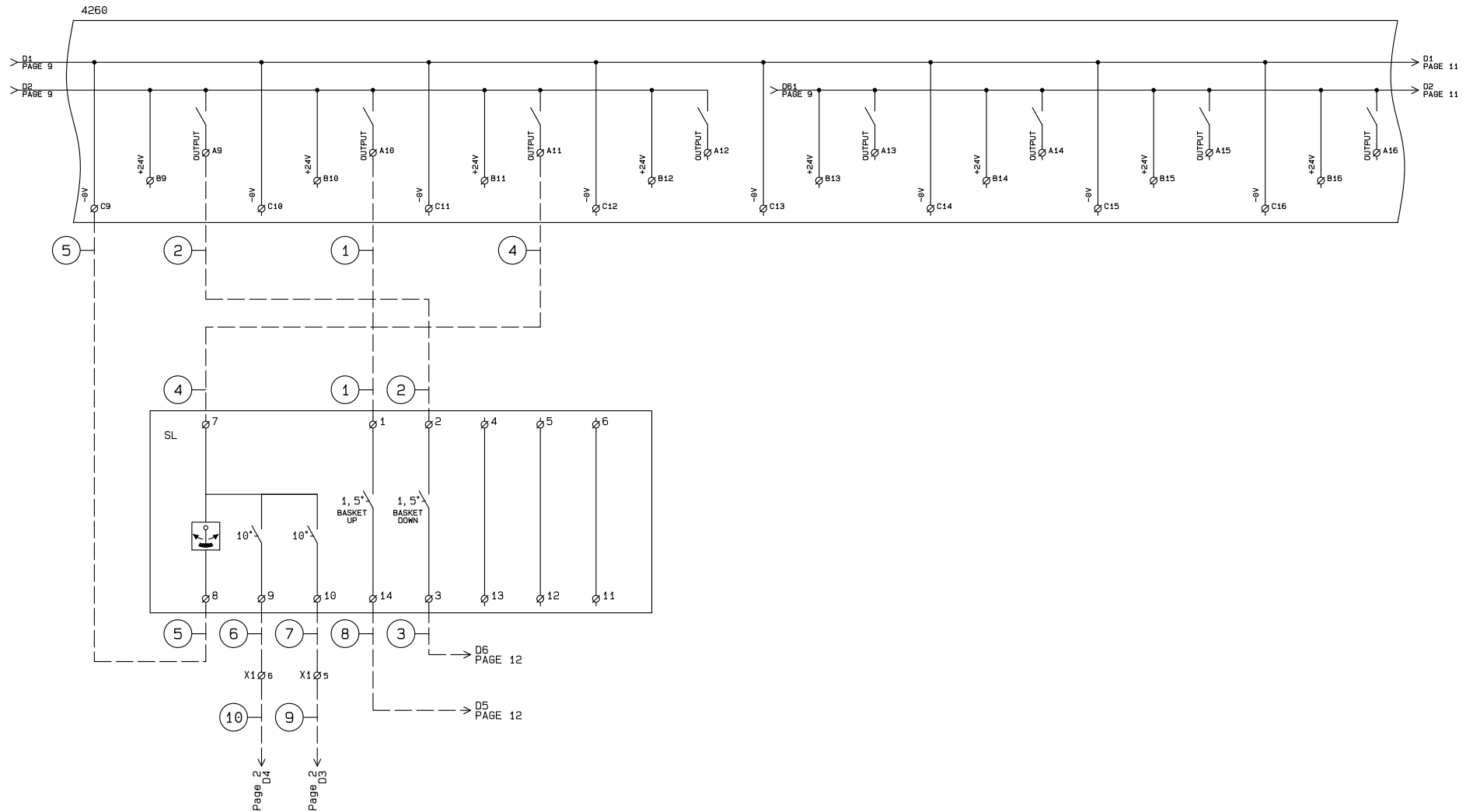

CONTROL BOX BASKET

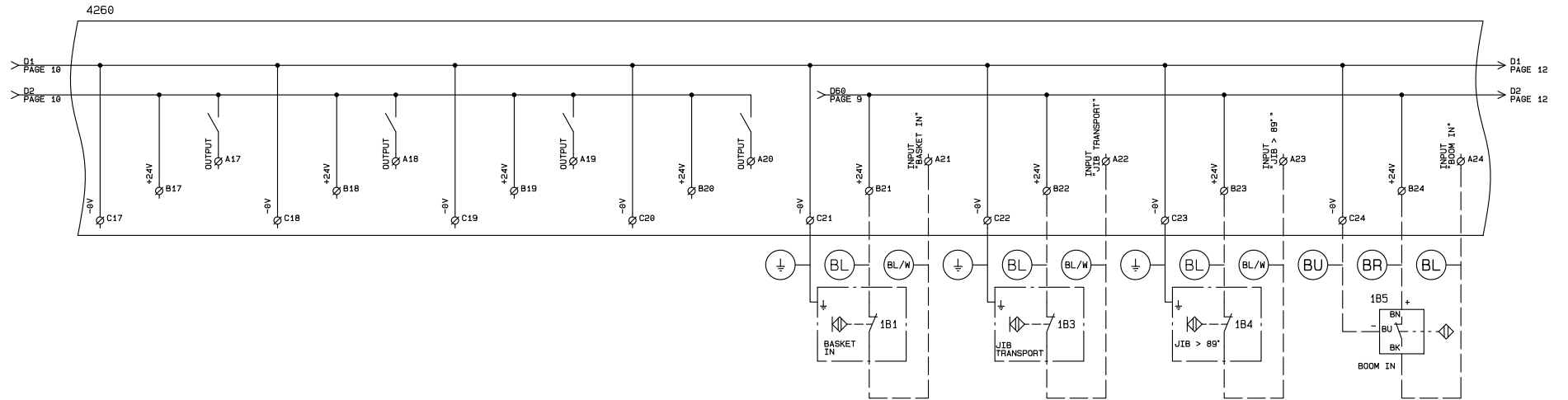

CONTROL BOX BASKET

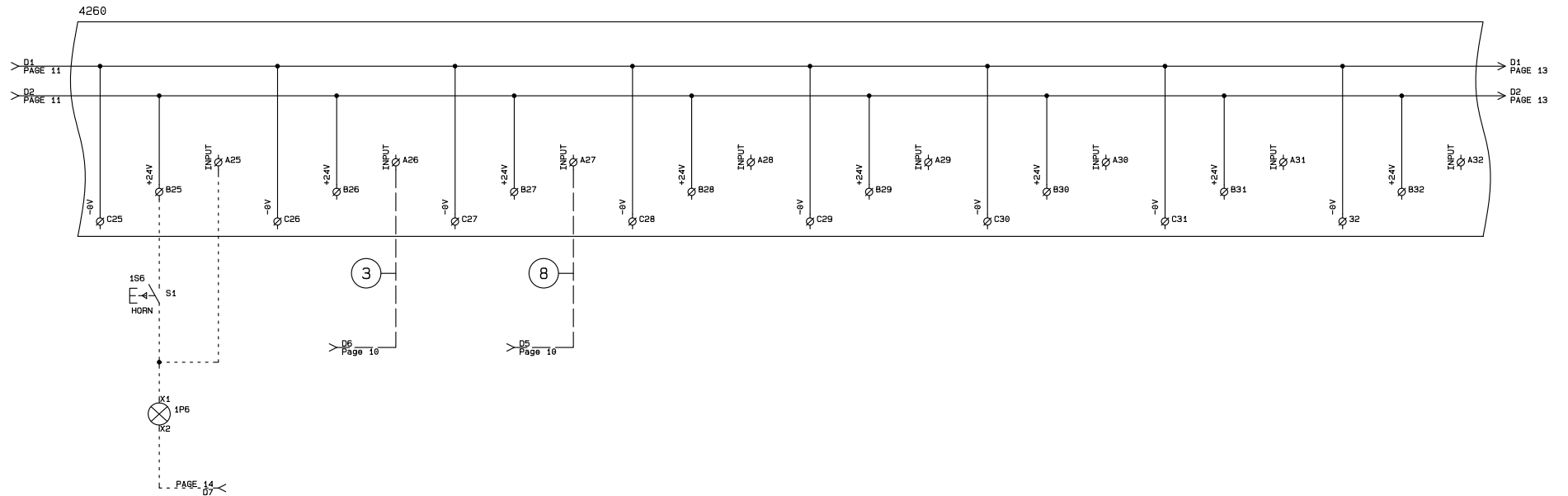

CONTROL BOX BASKET

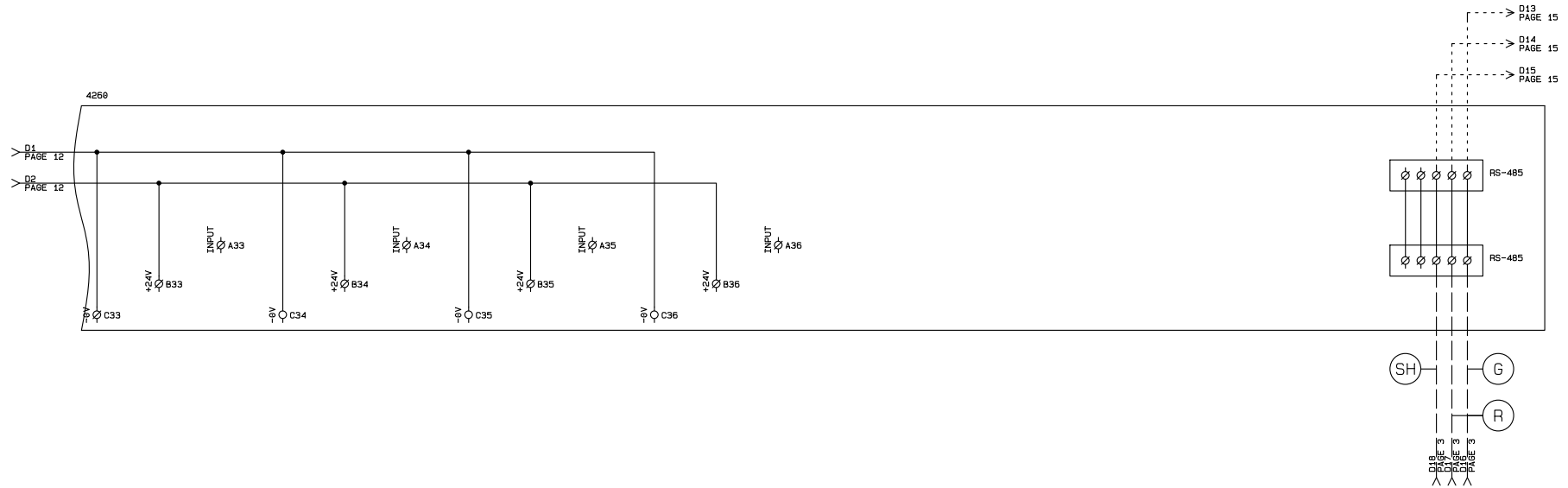

CONTROL BOX BASKET

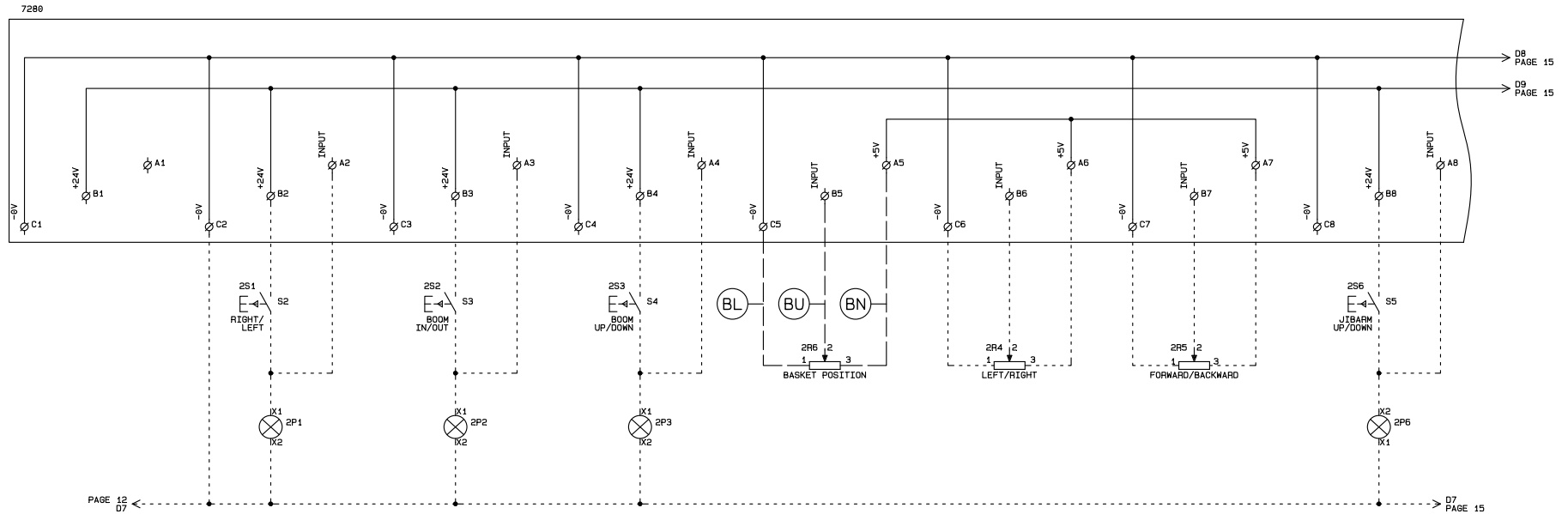

CONTROL BOX BASKET

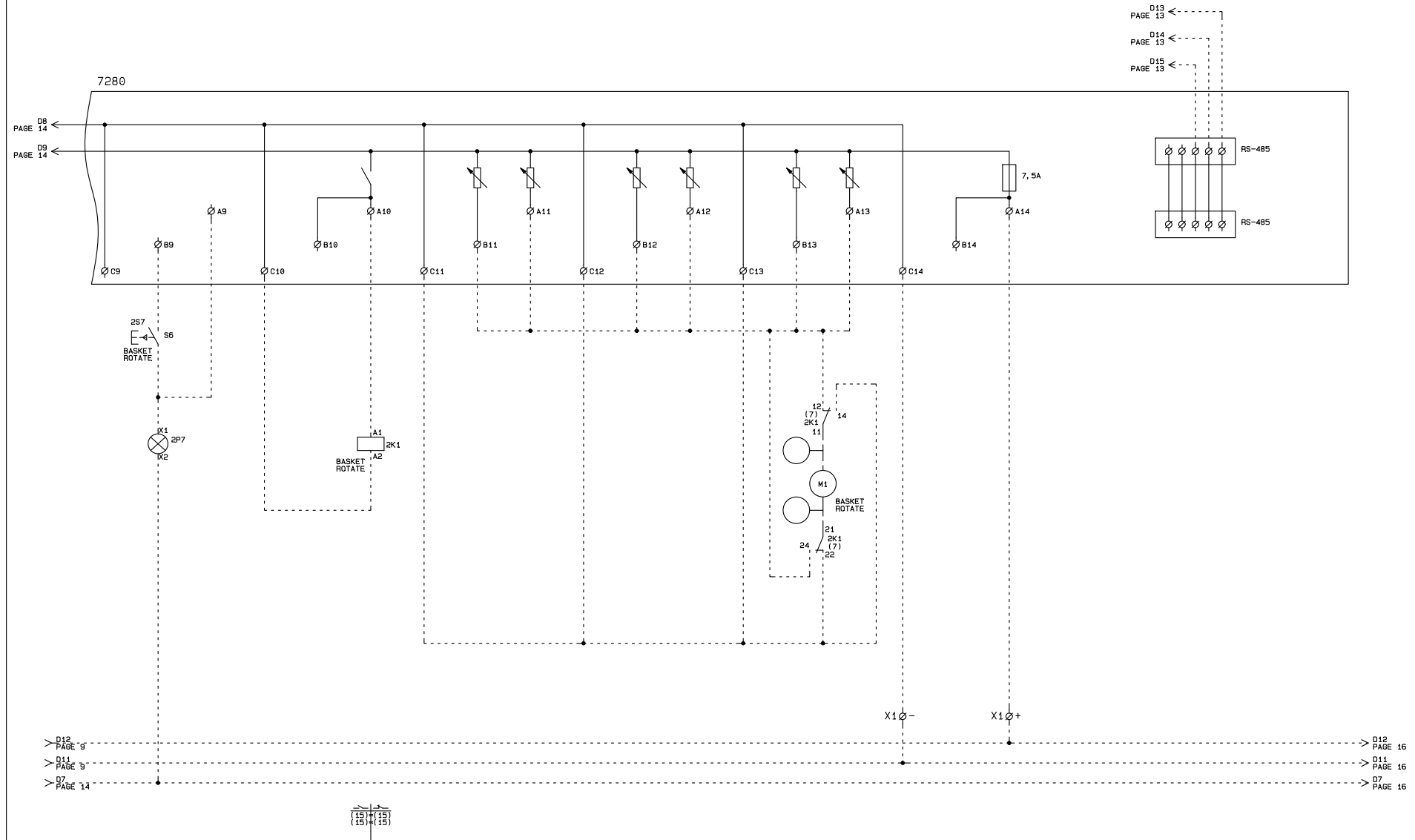

CONTROL BOX BASKET

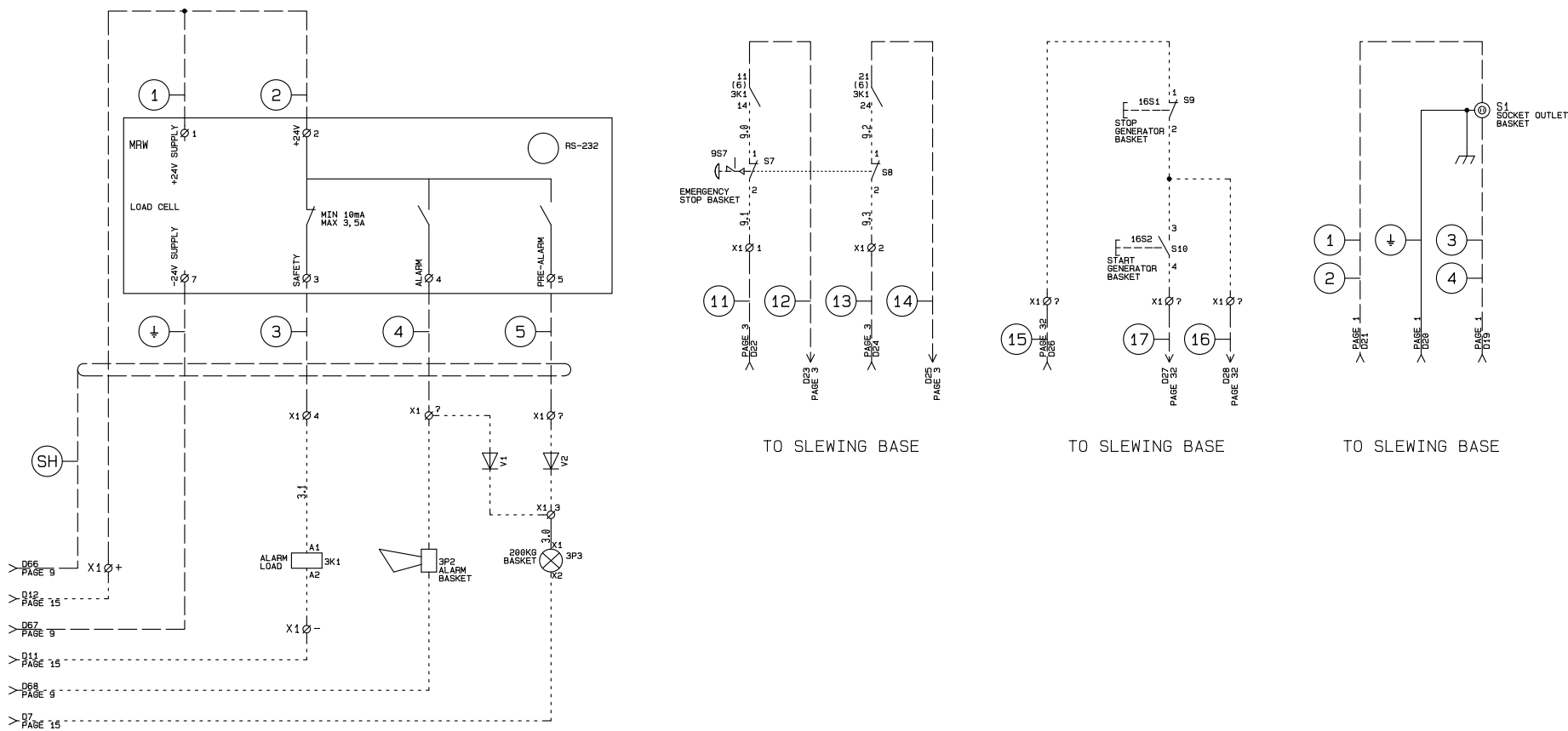

DENKA LIFT

Lift type : DLX15
 Extra equipment: -
 Drawn by : CTJ Approved by : CTJ

No : 13131 Hydraulics : -
 Date : 03.11.06 Rev. : -

Dia. No. : -
 Title : Basket
 Page : 16 of 32

CONTROL BOX CHASSIS

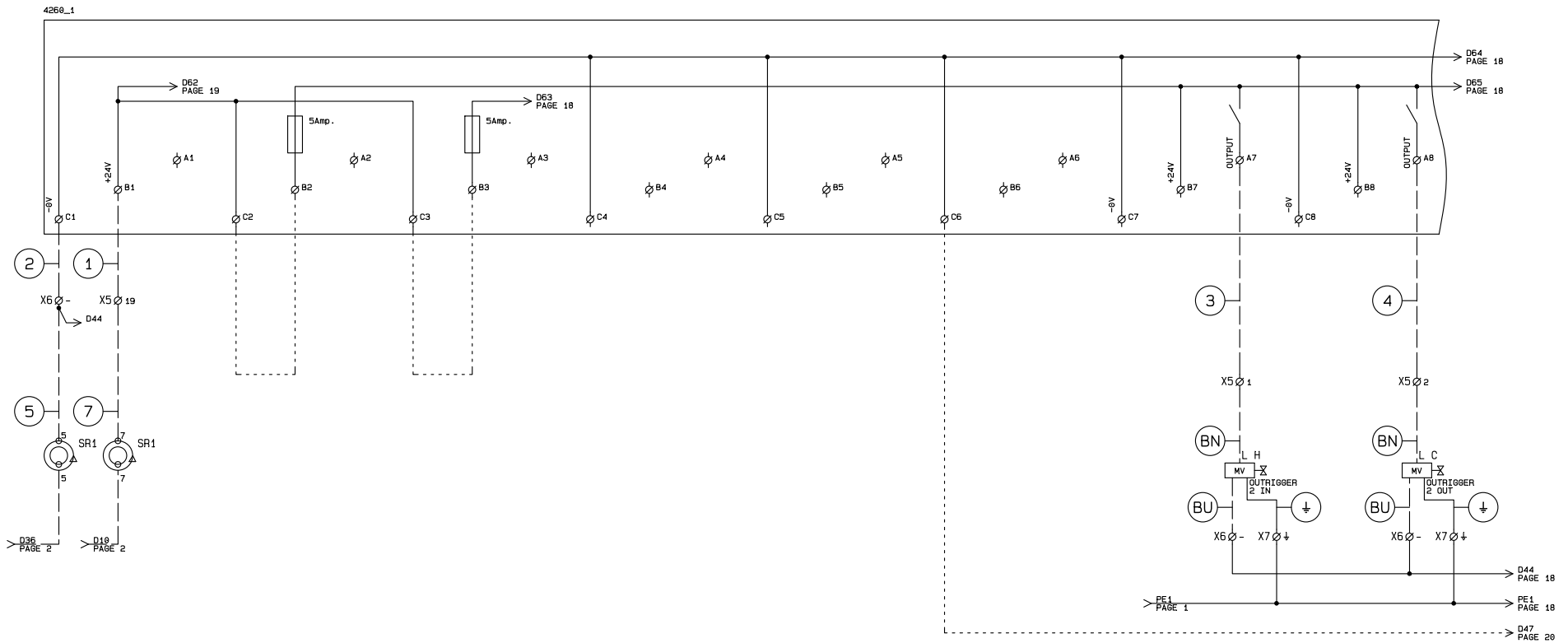

CONTROL BOX CHASSIS

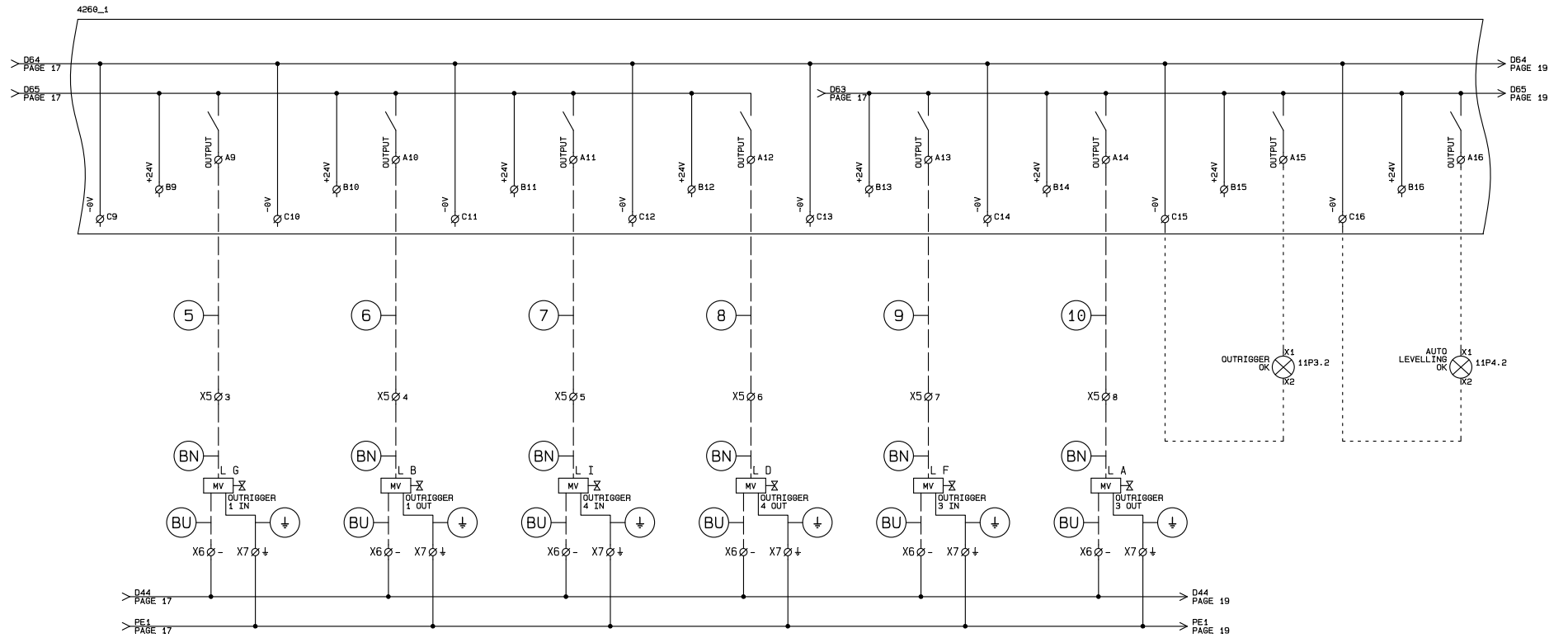

CONTROL BOX CHASSIS

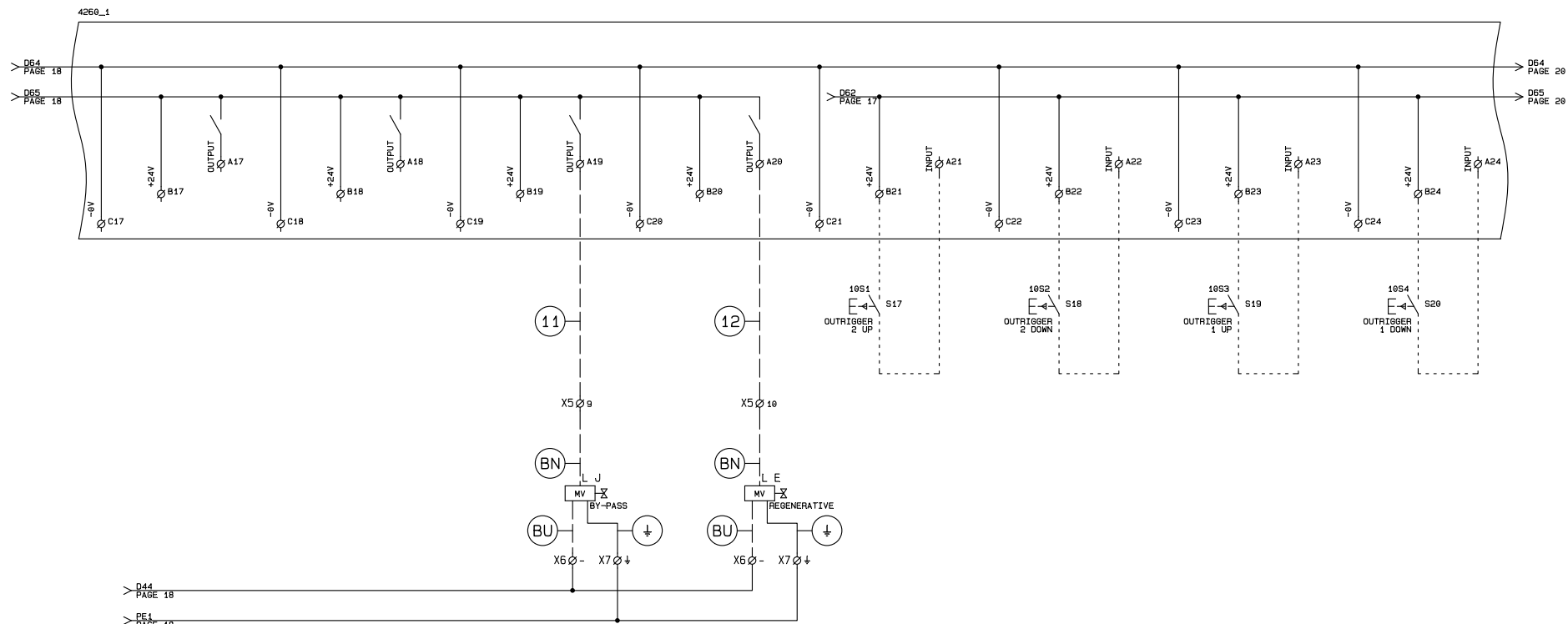

CONTROL BOX CHASSIS

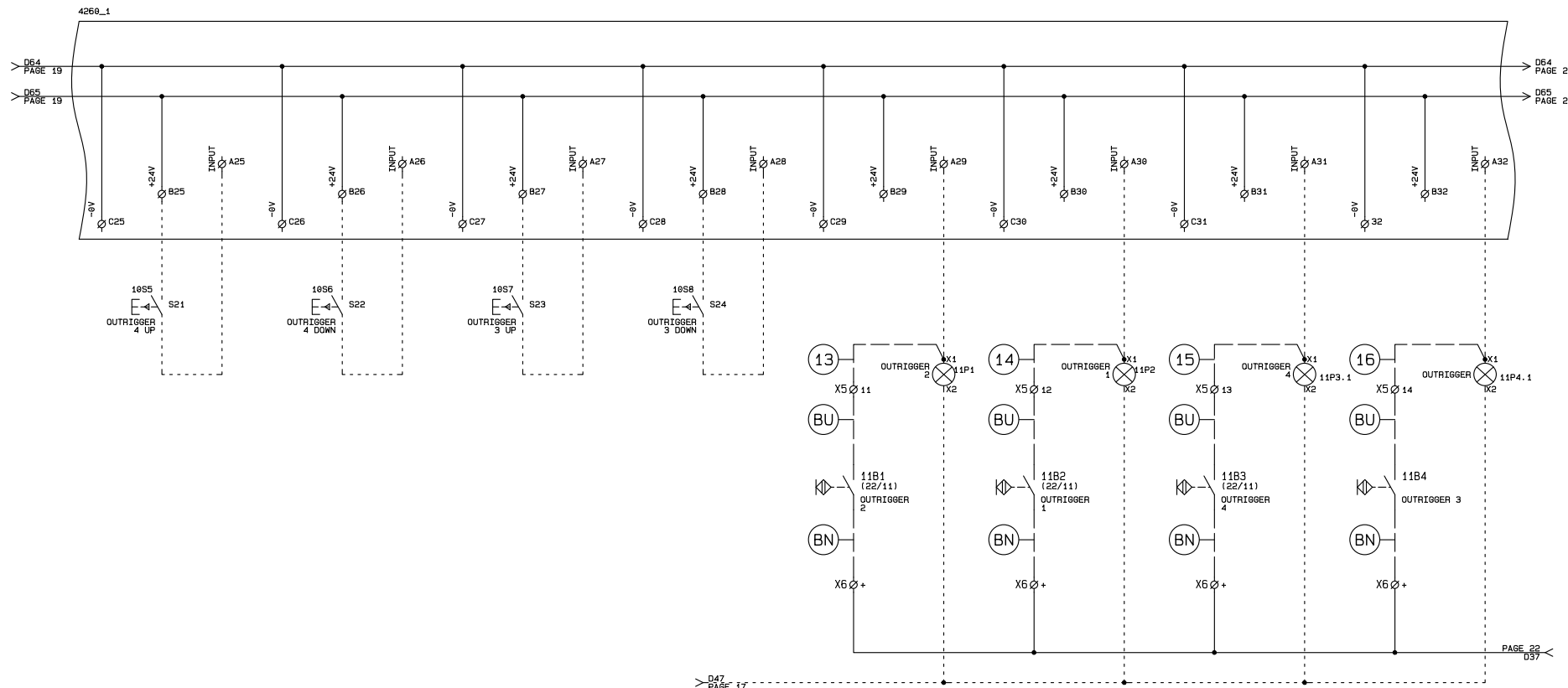

CONTROL BOX CHASSIS

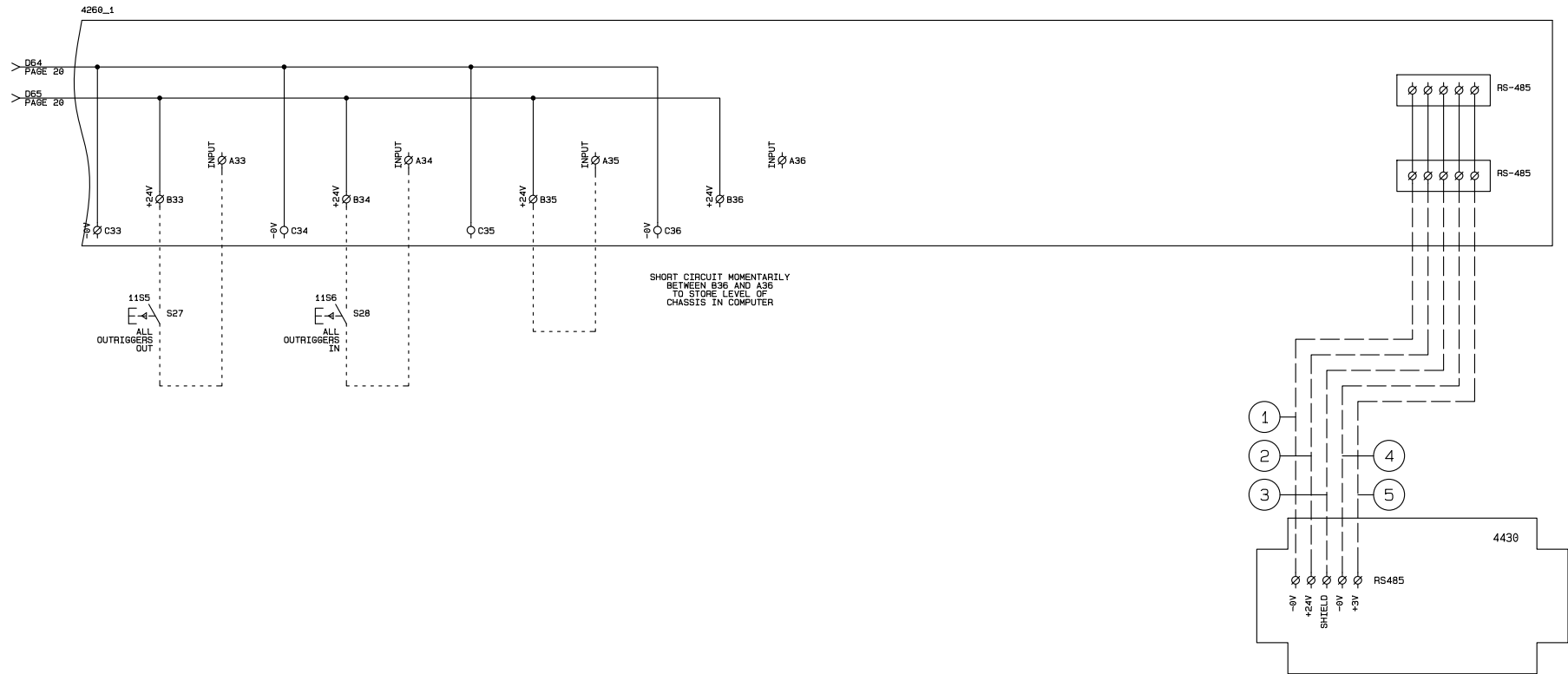

CONTROL BOX CHASSIS

TO SLEWING BASE

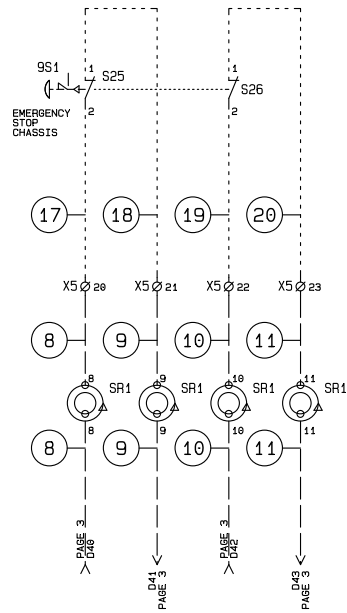

TO SLEWING BASE

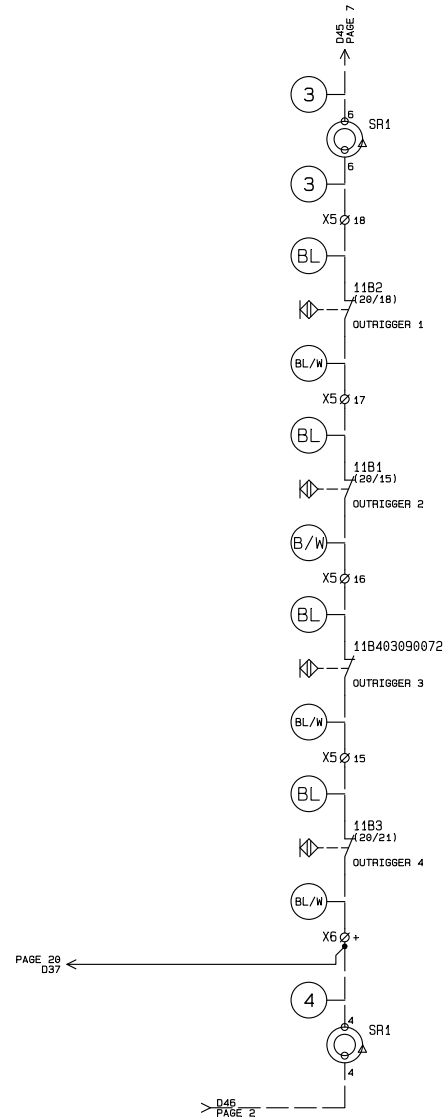

PAGE 20
D37

DENKA LIFT

Lift type : DLX15

No : 13131

Hydraulics : -

Dia. No. : -

Extra equipment: -

Title : Chassis

Højvang 5 4300 Holbæk Phone 59 45 55 00

Drawn by : CTJ

Approved by : CTJ

Date : 03.11.06 Rev. : -

Page : 22 of 32

CONTROL BOX SLEWING BASE

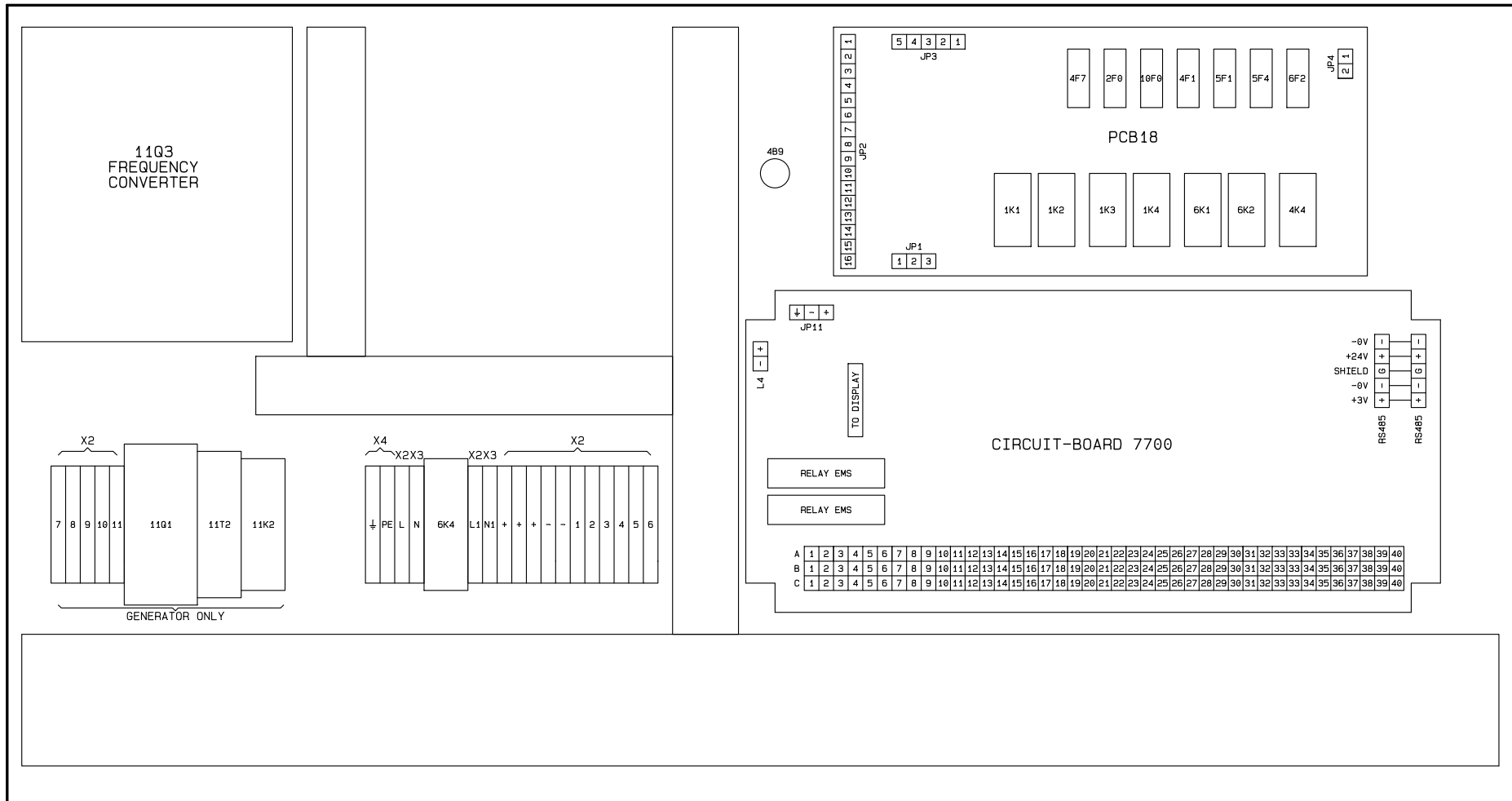

CONTROL BOX SLEWING BASE

MEMBRANE KEYBOARD

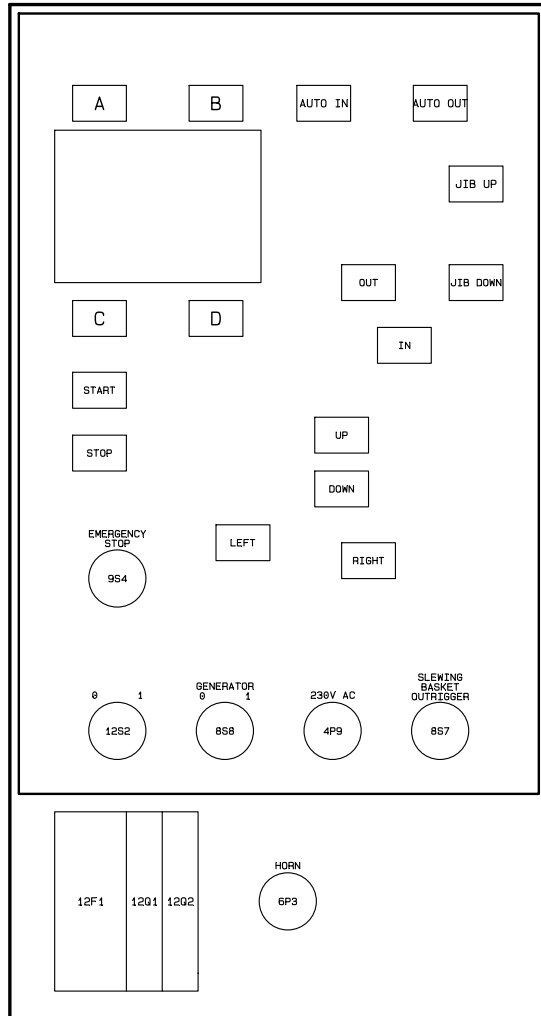

MAGNET COILS ON SLEWING BASE

SLEWING RIGHT L1	BOOM DOWN L2	BOOM OUT L3	JIB UP L4	BASKET UP L5	BY-PASS L6
SLEWING LEFT L7	BOOM UP L8	BOOM IN L9	JIB DOWN L10	BASKET DOWN L11	CHASSIS L12

DENKA LIFT

Lift type : DLX15

No : 13131

Hydraulics : -

Dia. No. : -

Extra equipment: -

Title : Layout slewing base

Højvang 5 4300 Holbæk Phone 59 45 55 00

Drawn by : CTJ

Approved by : CTJ

Date : 03.11.06 Rev. : -

Page : 24 of 32

CONTROL BOX BASKET

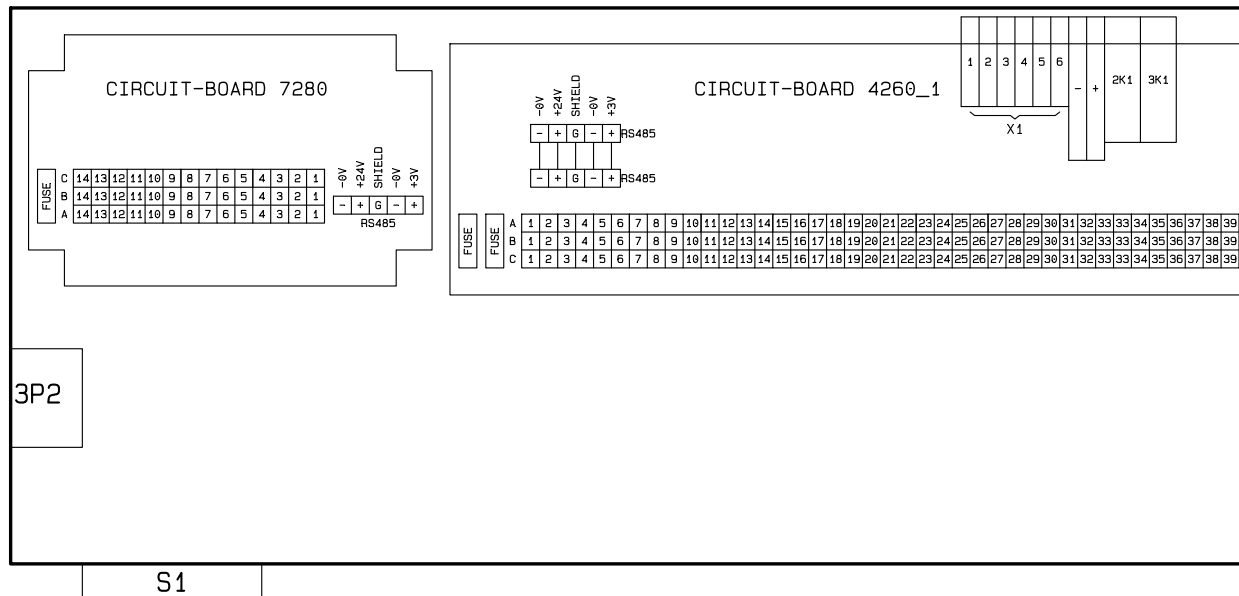
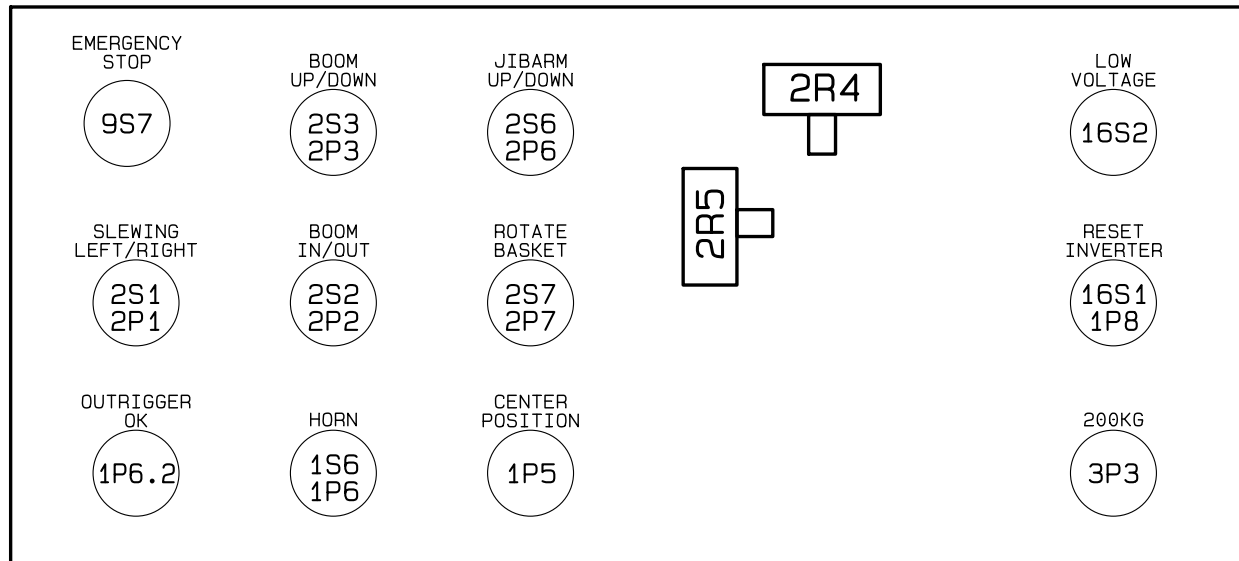

CONTROL BOX CHASSIS

CONTROL BOX CHASSIS

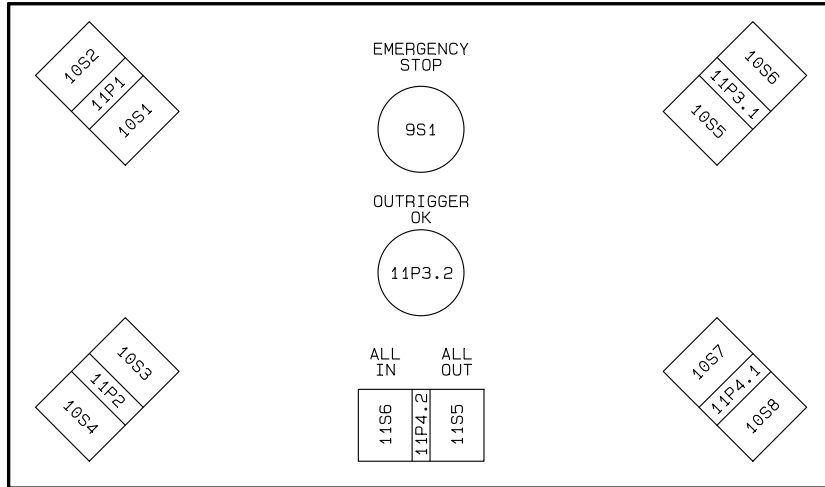

TERMINAL BOX UNDER CHASSIS

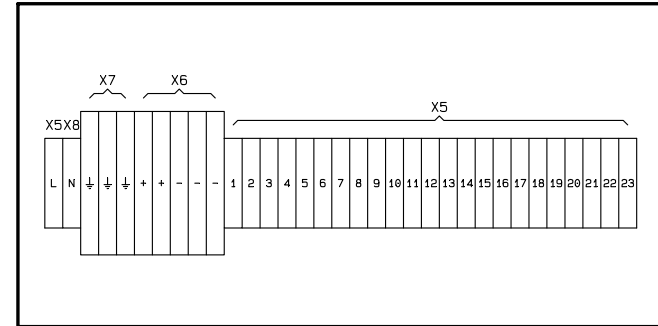

LEVELLING BOX UNDER CHASSIS

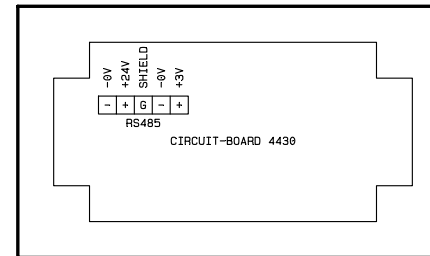

WALL SOCKET



CONTROL BOX CHASSIS

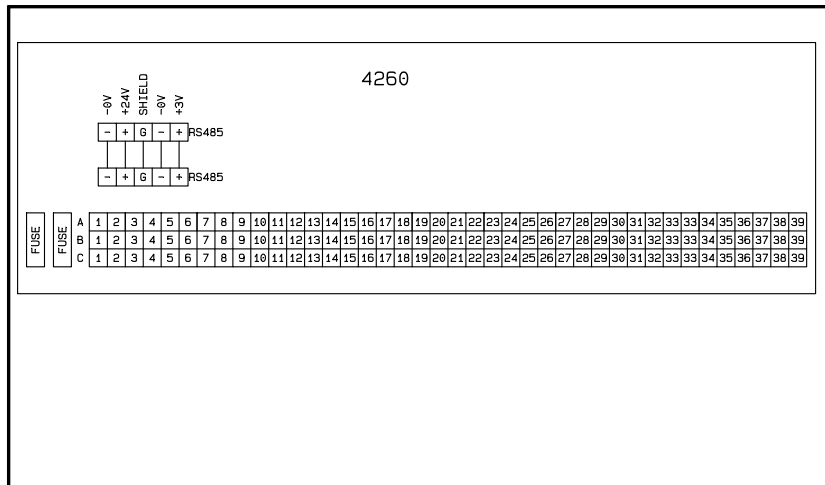

MAGNET COILS ON CHASSIS

OUTRIGGER 3 OUT L A	OUTRIGGER 1 OUT L B	OUTRIGGER 2 OUT L C	OUTRIGGER 4 OUT L D	REGENERATIVE L E
OUTRIGGER 3 IN L F	OUTRIGGER 1 IN L G	OUTRIGGER 2 IN L H	OUTRIGGER 4 IN L I	BY-PASS L J

DENKA LIFT

Lift type : DLX15

No : 13131

Hydraulics : -

Dia. No. : -

Extra equipment: -

Title : Layout chassis

Højvang 5 4300 Holbæk Phone 59 45 55 00

Drawn by : CTJ

Approved by : CTJ

Date : 03.11.06 Rev. : -

Page : 26 of 32

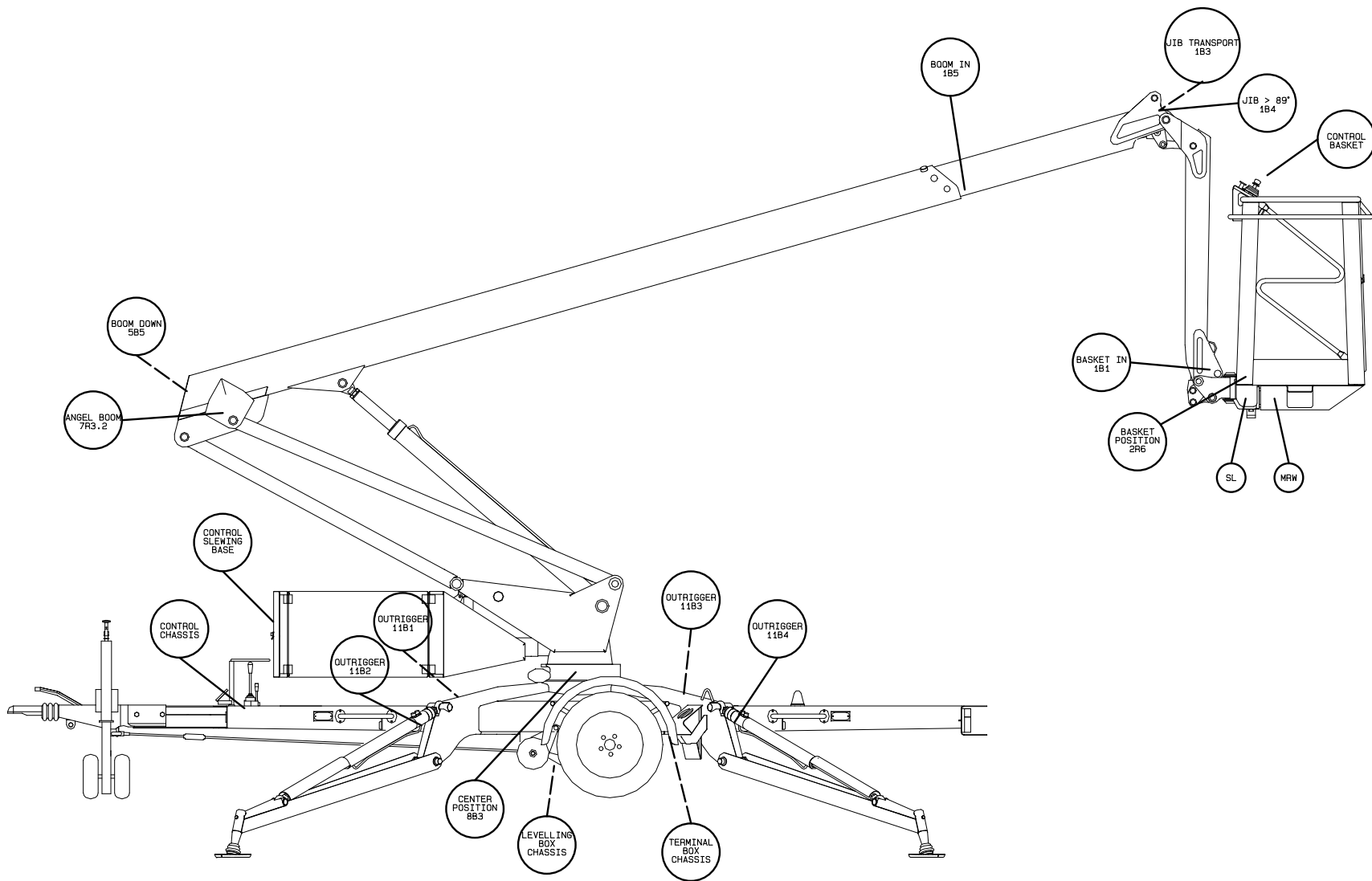

DENKA LIFT Højvang 5 4300 Holbæk Phone 59 45 55 00	Lift type : DLX15	No : 13131	Hydraulics : -	Dia. No. : -
	Extra equipment: -	Drawn by : CTJ	Approved by : CTJ	Title : Layout lift
		Date : 03.11.06	Rev. : -	Page : 27 of 32

TERMINALS

- X1 = TERMINALS BASKET
- X2 = DOBB. TERMINALS SLEWING BOX
- X3 = NEUTRAL TERMINALS SLEWING BOX
- X4 = EARTH TERMINALS SLEWING BOX
- X5 = SINGEL TERMINALS CHASSIS
- X6 = DOBB. TERMINALS CHASSIS
- X7 = EARTH TERMINALS CHASSIS
- X8 = NEUTRAL TERMINALS CHASSIS
- X9 = WALL SOCKET CHASSIS
- X10= BATTERI BOX

WIRE COLORS

- BL = BLACK
- Y = YELLOW
- BU = BLUE
- G = GREEN
- R = RED
- W = WHITE
- BR = BROWN
- SH = SHIELD

WIRE TYPE

- PRINTED CIRCUIT BOARD
- CONTROL CABINET
- OUT OF CONTROL CABINET

(X) — RED = CABLE BOOM

(X) — GREEN = CABLE SWIVEL JOINT

(X) — BLUE = CABLE DIVERSE

SYMBOL

 = KEY SWITCH

 = TWIST KNOB

 = PUSH BUTTON

 = EMERGENCY STOP

 = LAMP / LED

 = POTENTIOMETER

 = HORN

 = VALVE

 = RELAY

 = FUSE

 = AUTOMATIC FUSE

 = ELECTRIC SWIVEL JOINT

 = INDUCTIVE SENSOR

 = LIMIT SWITCH

 = FREQUENCY CONVERTER

 = POWER SUPPLY

 = EMC FILTER

 = NC

 = NO

DENKA LIFT

Lift type : DLX15

No : 13131

Hydraulics : -

Dia. No. : -

Extra equipment: -

Title : Info

Højvang 5 4300 Holbæk Phone 59 45 55 00

Drawn by : CTJ

Approved by : CTJ

Date : 03.11.06 Rev. : -

Page : 28 of 32

PARTSLIST

Machine type :DLX15
 Machine number : 13131
 Extra equipment : -

Denka Lift A/S
 Højvang 5
 DK-4300 Holbæk
 e-mail: info@denka.dk
 Phone +45 59 45 55 00
 Telefax. +45 59 44 21 55

Pos.	Description	Part No
1B1	Osiswitch limit XCMD2502L1	03090133
1B3, 1B4	Osiswitch limit XCMD2515L1	03091033
1B5, 8B3	Inductive sensor M12 5m	03410128
1K1..1K4, 3K1, 6K1, 6K2	Relay, CA 4-9C 24VDC, S+S	03410506
1P5, 1P6, 1P6.2, 2P1..2P3, 2P6, 2P7, 11P3.2, 11P4.2	LED block green ZBVB3	03090161
1S6, 2S1..2S3, 2S6, 2S7	Push button green LED ZB4BA333	03090167
2F0, 10F0	Auto blade fuse 7,5A brown	03410300
2K1, 4K4, 6K4	Relay 24VDC 2pole	03410080
2R4..2R6	Potentiometer, 6639 10Kê 1W	03470122
3P2	Piezokeramic horn	03080080
3P3, 11P1, 11P2, 11P3.1, 11P4.1	LED block red ZBVB4	03090162
4B9	Bimetal thermostat NC 20°C	03420173
4E9	Heating elem 230x110mm 24V 50W	03420172
4F1, 5F1, 5F4, 6F2	Auto blade fuse 5A beige	03410301
4F7	Auto blade fuse 10A Red	03410302
4P9	LED green 230VAC ZB4BVM3	03090176
5B5	Limit switch, XCK-P518	03090019
6P3	El. Horn	03080079
7R3.2	Potentiometer 10K IP65	03470123
8P1	LCD display 320x240Dot	03410614
8S1	DLX 15 Membrane keyboard	03040043
8S7	Twist knob ZB4BD3 3 pos.	03090151
8S8	Twist knob ZB4BD5 3 pos.	03090153

Dia No :-

Drawn by : CTJ

Approved by : CTJ

Date : 03.11.06

Revision : -

Page : 29 of 33

PARTSLIST

Machine type :DLX15
 Machine number : 13131
 Extra equipment : -

Denka Lift A/S
 Højvang 5
 DK-4300 Holbæk
 e-mail: info@denka.dk
 Phone +45 59 45 55 00
 Telefax. +45 59 44 21 55

Pos.	Description	Part No
9S1	Emergency stop ZB5AS844	03090137
9S4, 9S7	Emergency stop ZB4BS844	03090155
10S1..10S8, 11S5, 11S6	Dobb button W/B ZB5AW811723	03130077
11B1..11B3	Limit switch, XCMA-110 (5)	03090072
11K2	Relay, 2-pol 12VDC 6A	03410064
11Q2	Relay 12A 24VDC, LC1D128JD	03090147
11Q3	Freq. converter 2,2 kW 1x230V	03420190
11T2	Timer multifkt 24-230V, ODQ1	03090125
11T3	Filter freq. converter 1x230V	03420191
12F1	ELCB 30mA 1P+N 40Amp.	03410617
12Q1, 12Q2	Automatic fuse, 10A	03410009
12S2, S5	Key switch top ZB4BG2	03090154
12T5	Power supply 230v/24vdc 10A	03420171
16S1	Push button red ZB4BA4	03090166
16S2	Push button green ZB4BA3	03090165
4260, 4260_1	Printed Circuit board 4260	03090143
4430	Levelling PCB chassis 4430	03090146
7280	Prop valve control PCB 7280	03410611
7700	SPLC PCB 7700	03410612
7790	PCB for display 7790	03410613
D2	Diode, 3 Amp. 400V	03480103
L1..L12, L A, L B, L C, L D, L E, L F, L G, L H, L I, L J	Valve connector 3x0,75 / 5m	03240160
M1	Actuator cpl. 150mm	03360030
M2	Motor 2,2KW/1410b3/b5	03300093

Dia No :-

Drawn by : CTJ

Approved by : CTJ

Date : 03.11.06

Revision : -

Page : 30 of 33

HONDA GENERATOR

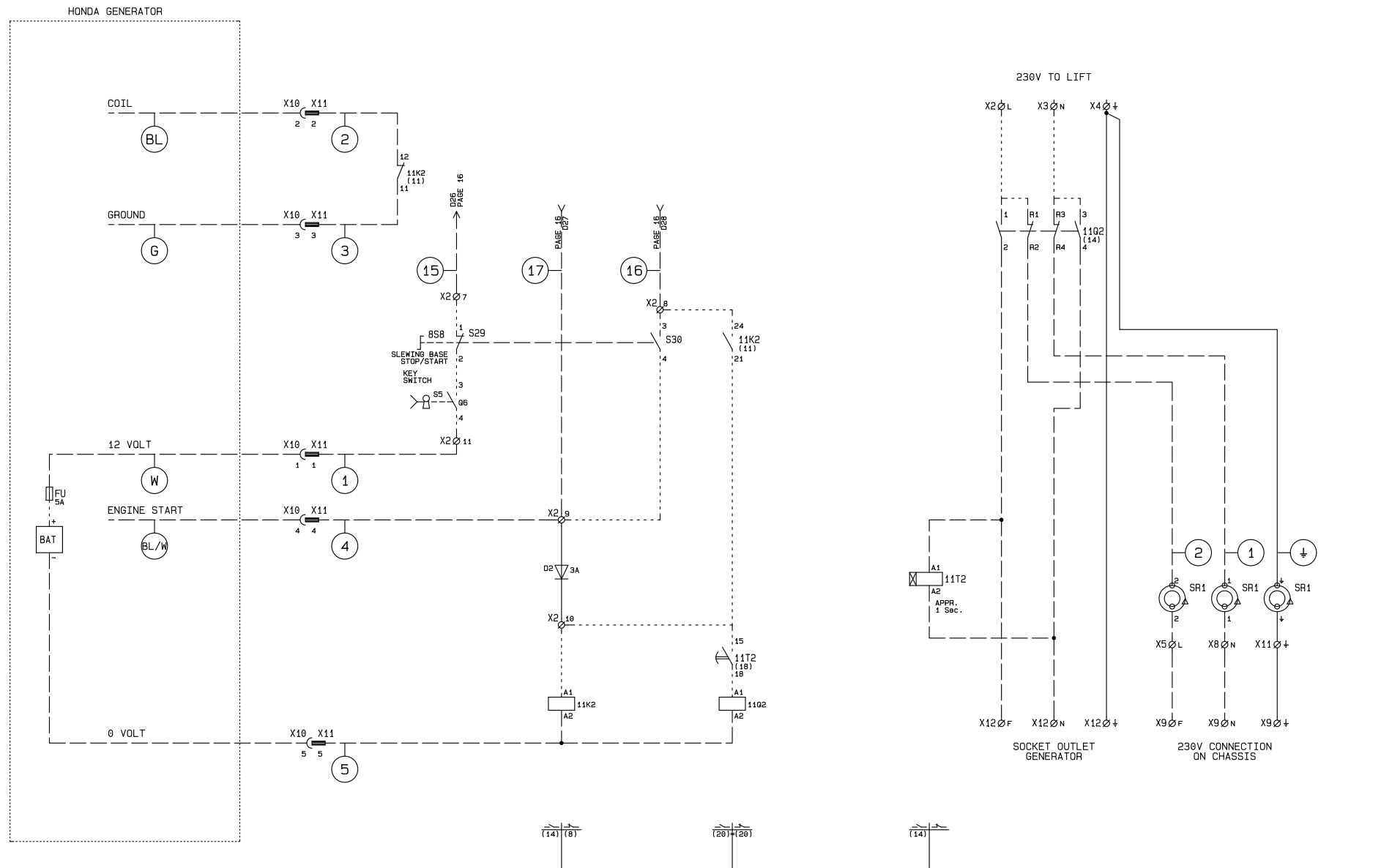

DENKA LIFT

Lift type : DLX15

No : 13131

Hydraulics : -

Dia. No. : -

Extra equipment: -

Title : Generator

Højvang 5 4300 Holbæk Phone 59 45 55 00

Drawn by : CTJ

Approved by : CTJ

Date : 03.11.06 Rev. : -

Page : 32 of 32