

<h1>DENKA LIFT</h1>	Lift type : DL21 RBW NORSK	No : 11131	Hydraulics : Atos On/Off Ver.2	Dia No. : 04015402
	Extra equipment: EL-BETJENT UNDERVOGN, PRIORITERING, 3 HØJDER	Drawn by : MSG	Approved by : JJ REGSTRUP INST	Title : Nøkkelskema
Højvang 5 4300 Holbæk Phone 59 45 55 00		Date : 11-01-00 Rev. :		Page : 1 of 15

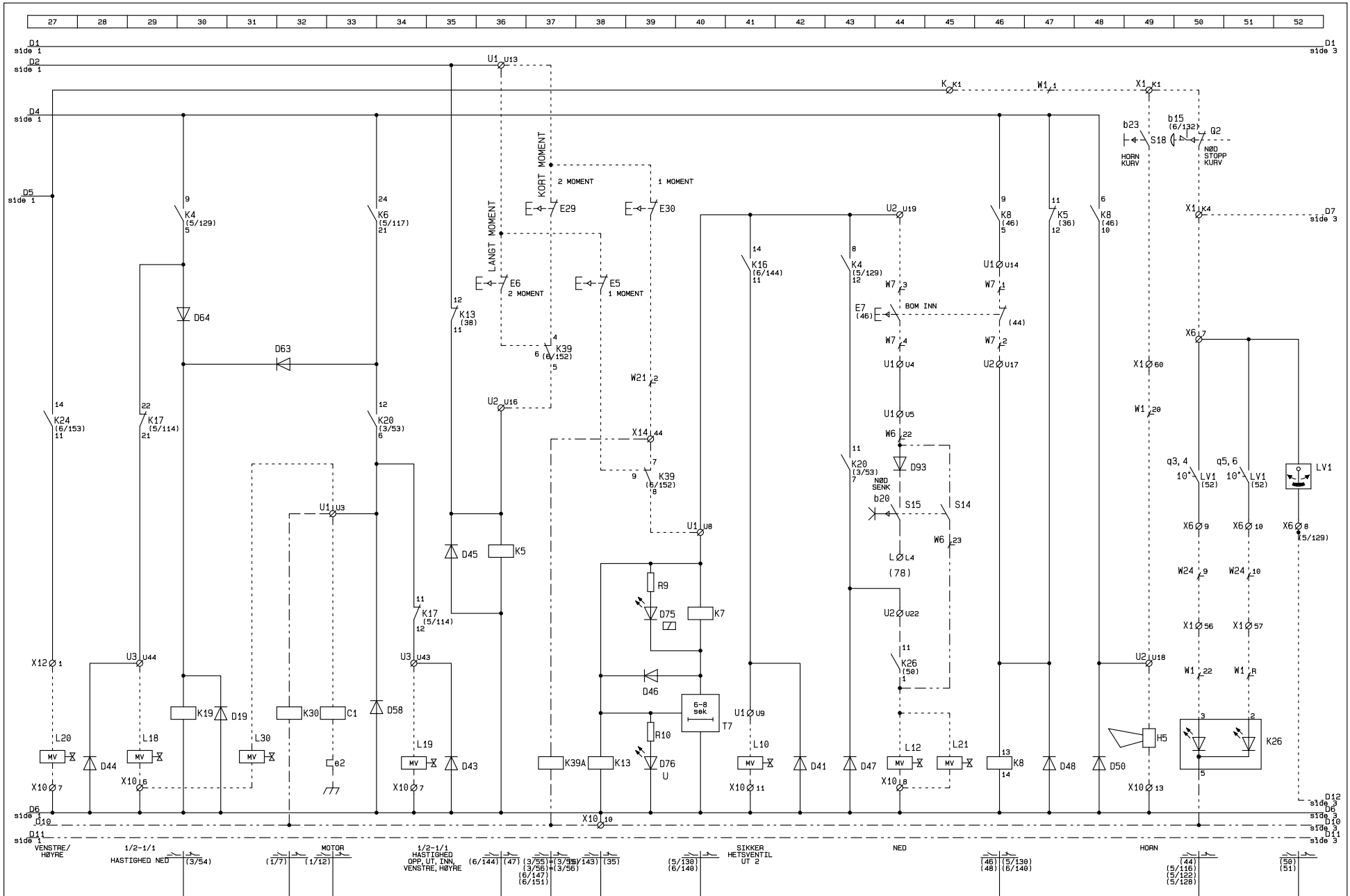

DENKA LIFT	Lift type : DL21 RBW NORSK	No : 11131	Hydraulics : Atos On/Off Ver.2	Dia No. : 04015402
	Extra equipment: EL-BETJENT UNDERVOGN, PRIORITERING,		3 HØJDER	Title : Nøkkelskema
Højvang 5 4300 Holbæk Phone 59 45 55 00	Drawn by : MSG	Approved by : JJ REGISTRUP INST	Date : 11-01-00 Rev. :	Page : 2 of 15

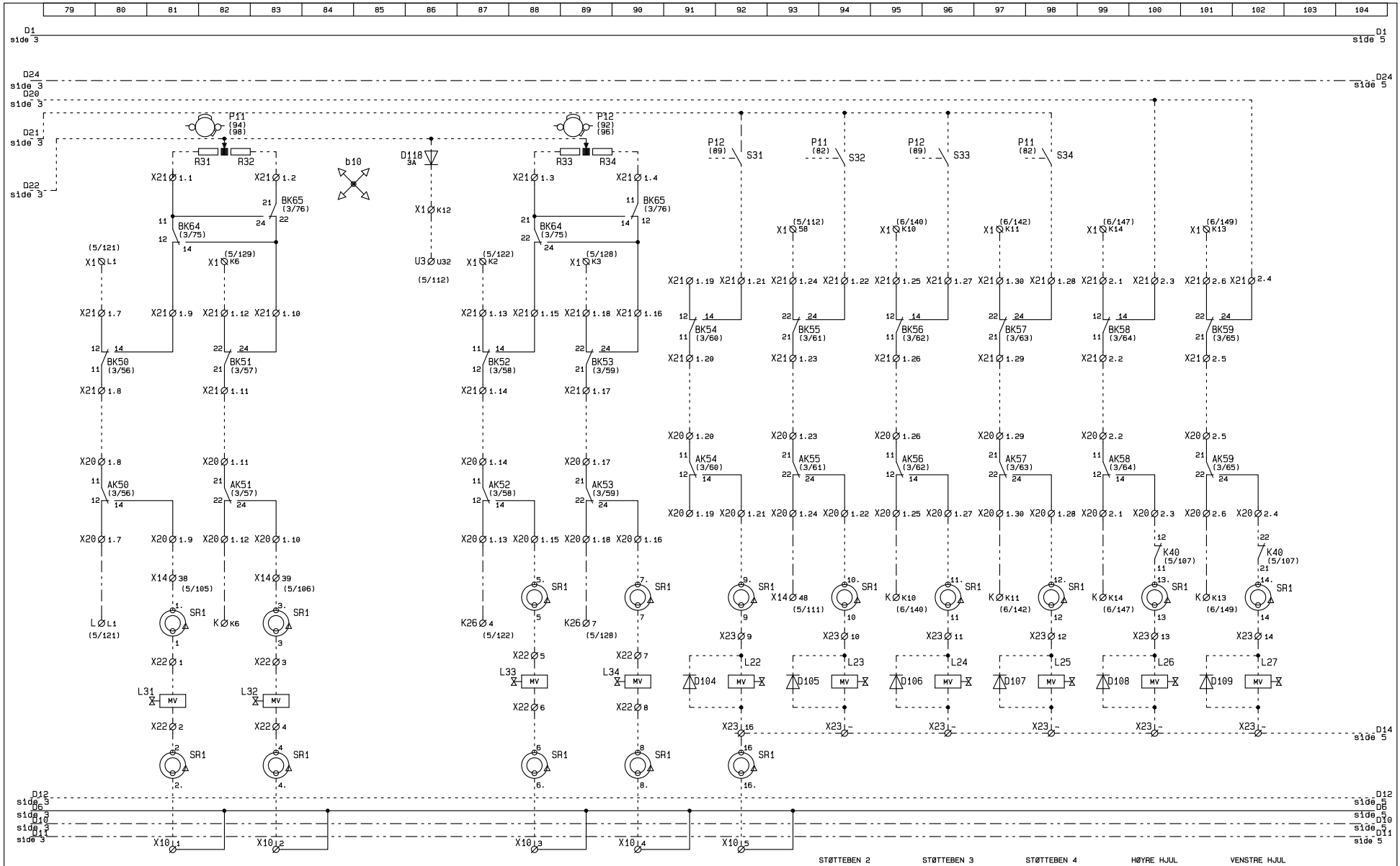

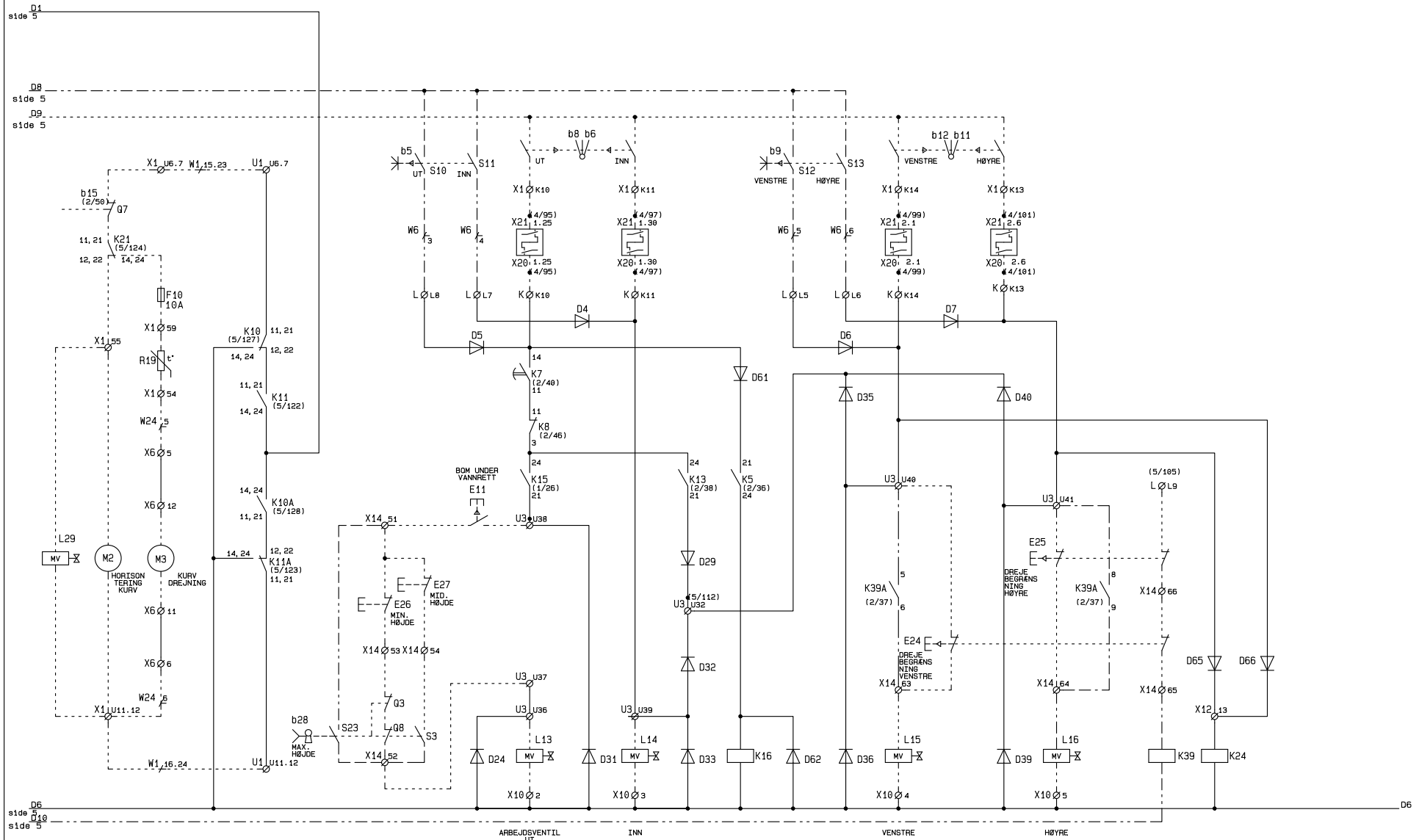

ARBEJDSVENTIL UT INN VENSTRE HØYRE

(2/741)

(2/37) (2/38) (2/39) (2/31) (2/27)
 (2/39) (2/38) (2/39) (2/31) (2/27)
 (3/53) (3/53) (3/53) (3/53) (3/53)
 (3/54) (3/54) (3/54) (3/54) (3/54)

BETJENING KURV

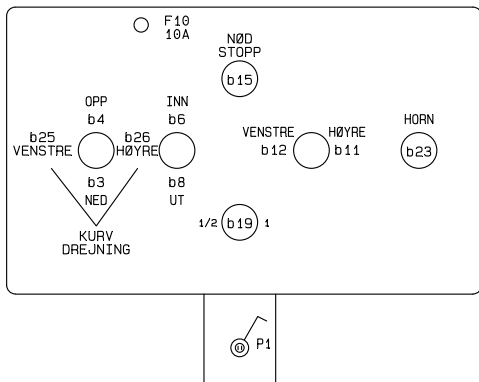

KOBLINGS BOKS UNDER CHASSIS

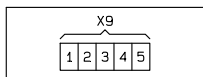

230V TILSLUTNING PÅ CHASSIS



KOBLINGS BOKS PÅ KURV

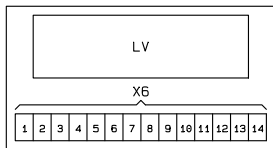

MAGNETVENTILER

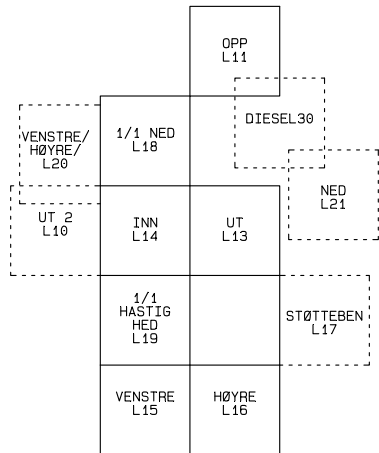

— PRINT
 - - - - - STYREKASSE
 - - - - - UT STYREKASSE

X20.1

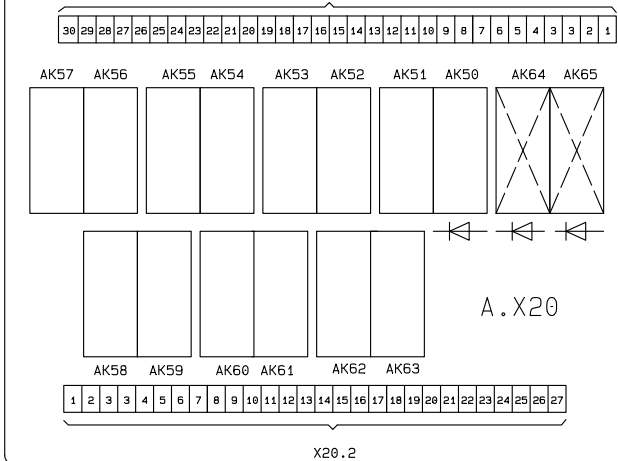

A.X20

LOKK STYREKASSE

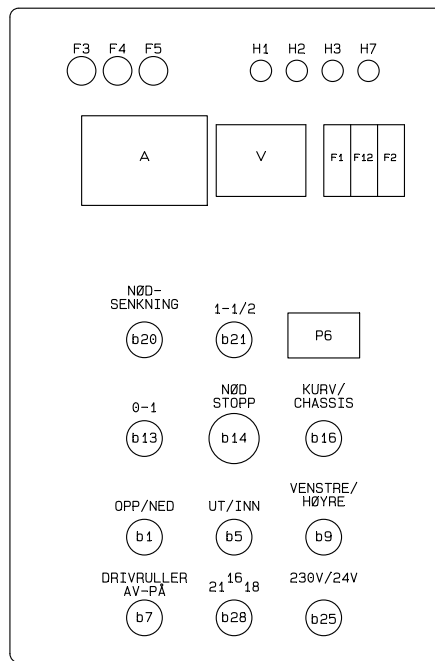

KLEMMER REKKE KURV

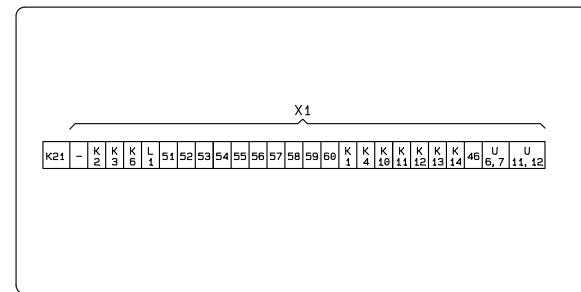

INNHOOLD STYREKASSE

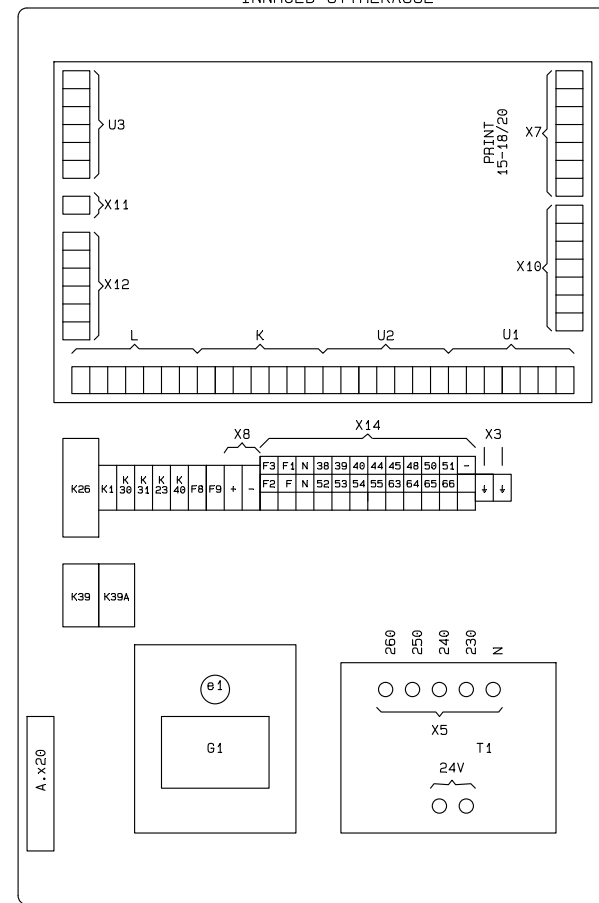

DENKA LIFT

Lift type : DL21 RBW NORSK

No : 11131

Hydraulics : Atos On/Off Ver.2

Dia No. : 04015402

Extra equipment: EL-BETJENT UNDERVOGN, PRIORITERING,

3 HØJDER

Title : Placeringsdiagram

Højvang 5 4300 Holbæk Phone 59 45 55 00

Drawn by : MSG

Approved by : JJ REGSTRUP INST

Date : 11-01-00 Rev. :

Page : 7 of 15

KOBLINGS BOKS PÅ CHASSIS

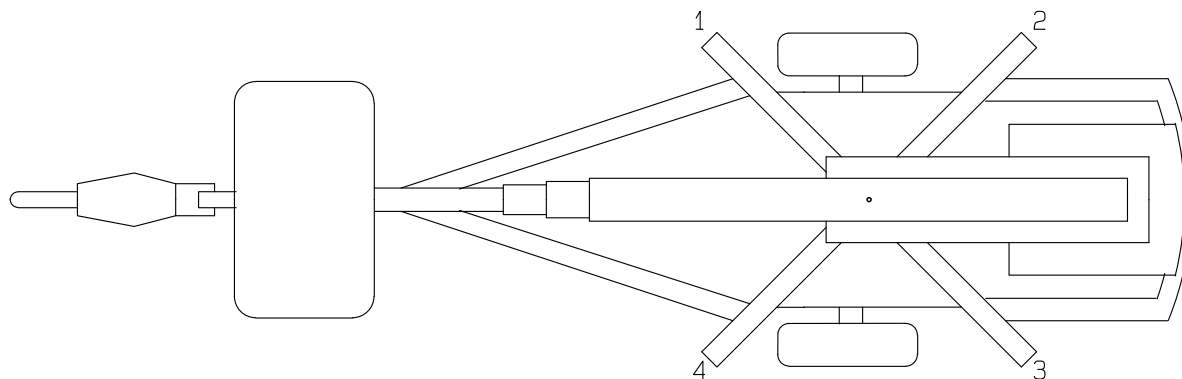
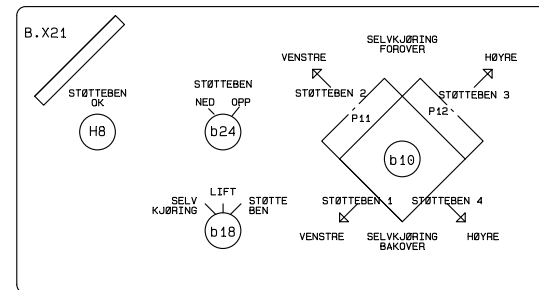
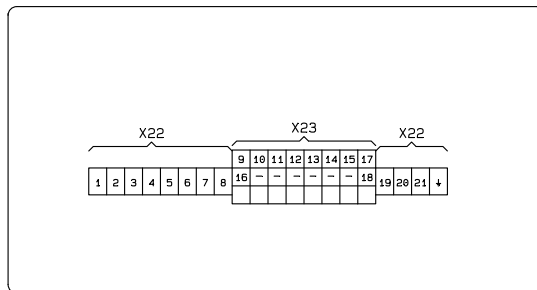
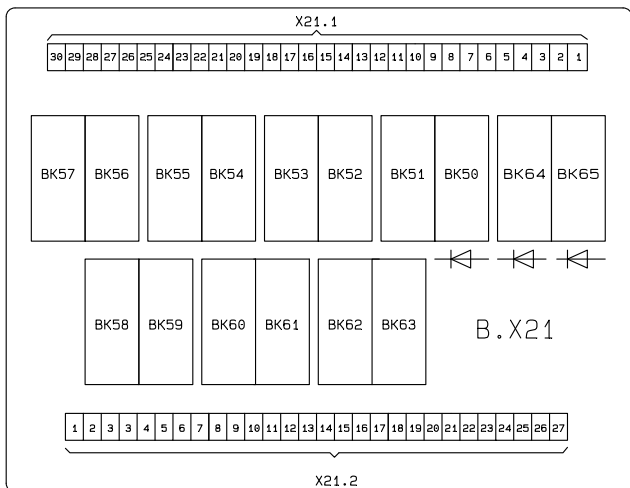

L34				
	STØTTEBEN 3	SELV KJØRING HØYRE	STØTTEBEN 1	FRI
	L24	L26	L22	
L33				

L32				
	STØTTEBEN 4	SELV KJØRING VENSTRE	STØTTEBEN 2	DRIV RULLER
	L25	L27	L23	L28
L31				

- 2 SIDELYS
- 3 HØYRE/VENSTRE BLINK
- 4 HØYRE/VENSTRE BAKLYS
- 5 STOPP
- 6 SKILTLYS
- 7 TÅGEBAGLYS
- LEDNINGNUMMERE

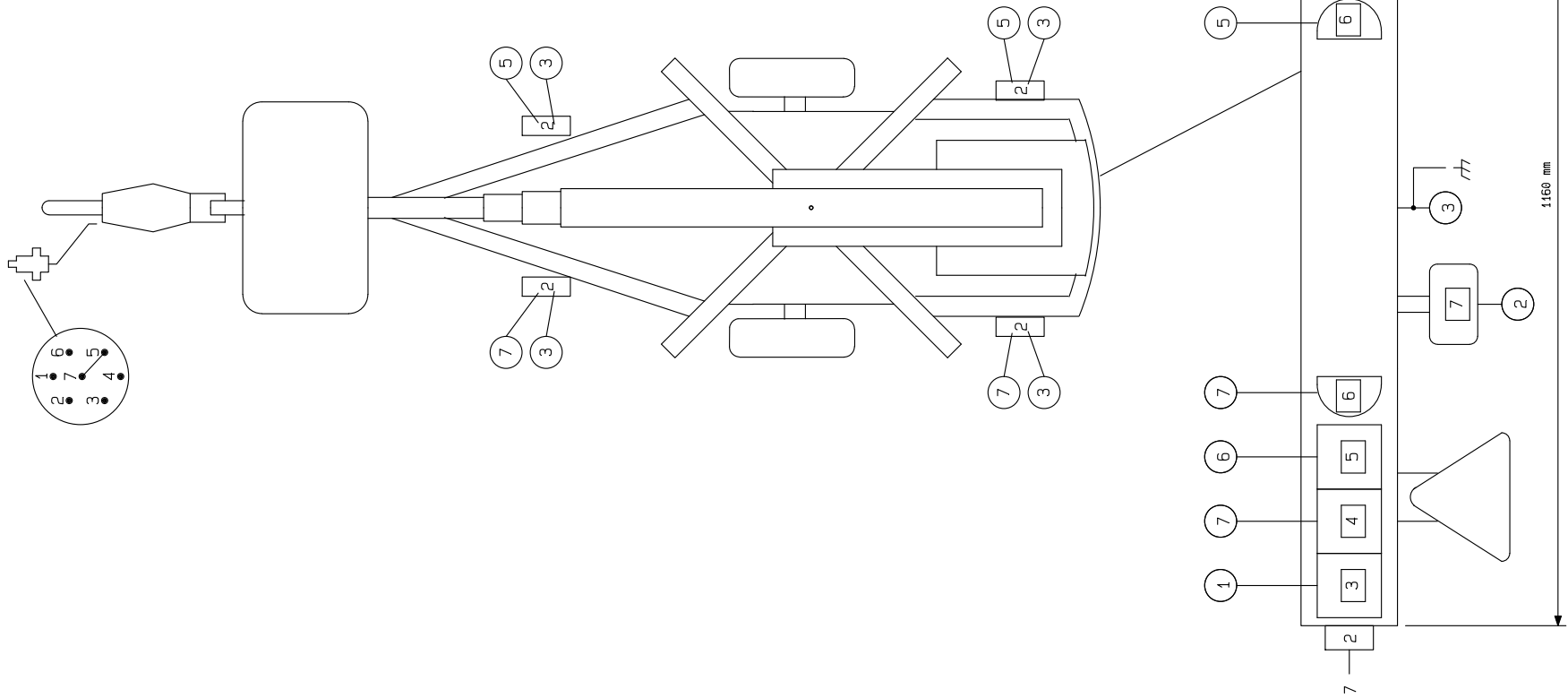

DENKA LIFT

Lift type : DL21 RBW NORSK

No : 11131

Hydraulics : Atos On/Off Ver.2

Dia No. : 04015402

Extra equipment: EL-BETJENT UNDERVOGN, PRIORITERING,

3 HØJDER

Title : Lyspanel

DELELISTE

Maskin type : DL21 RBW NORSK

Maskin nr : 11131

Ekstra udstyr : EL-BETJENT UNDERVOGN, PRIORITERING, 3
HØJDER

Denka Lift A/S
Højvang 5
DK-4300 Holbæk
e-mail: INFO@DENKA.dk
Tel. +45 59 45 55 00
Fax. +45 59 44 21 55

Navn	Benevnelse	Varenr.
H5	Horn, 24V	03080016
E5, E6, E29, E30	Endestopp, XCK-J561	03090003
E24, E25	Endestop, XCK-J70531	03090009
E7	Endestopp, XCK-M521	03090013
E9	Endestopp, XCK-S141	03090023
E11	Endestopp, XCK-S541	03090033
E26, E27	Endestopp, XCK-J565	03090048
E12	Endestopp XCMA-102 (5)	03090070
E20..E23	Endestopp, XCK-P502	03090101
L10, L17..L30	Spole, CCS0 24D	03240005
L11, L13..L16	Magnetspole, DHI 24V DC	03240021
L12	Spole, LISK 36W 24V	03240034
L31..L34	Magnetspole, SP-60Z0A-1-1-00/24DC	03240082
M1	El.motor, 24MC 42 THWA	03300004
e2	Termobryter, 755 KTS f. Hesselman	03300017
M2	El.motor, kpl. Pavalux	03300029
C1	Startrele, 0333 006 006	03300052
M3	Motordel, 30-24V DC	03360011
B1..B4	Batteri 24015 6V	03390004
V	Voltmeter, KM 48	03400001
A	Amperemeter, GB R59M 0/50A	03400007
P6	Timetæller, Digital 48x24 TY.1 12-24 VDC	03400020
F4, F5	Glassikring, 4A	03410005

Dia No : 04015402

Tegnet af : MSG

Godkendt af : JJ REGSTRUP INST

Dato : 11-01-00

Revision :

Side: 11

af 15

DELELISTE

Maskin type : DL21 RBW NORSK

Maskin nr : 11131

Ekstra udstyr : EL-BETJENT UNDERVOGN, PRIORITERING, 3
HØJDER

Denka Lift A/S
Højvang 5
DK-4300 Holbæk
e-mail: INFO@DENKA.dk
Tel. +45 59 45 55 00
Fax. +45 59 44 21 55

Navn	Benevnelse	Varenr.
F10	Glassikring, 10A	03410006
F3	Glassikring, 16A	03410007
F11	Sikring, 125A Din 00	03410008
F1, F12	Automatsikring, 10A	03410009
F2	Automatsikring, 50A	03410010
K2, K23	Rele, dobbelt 19/29V	03410020
K1, K30, K31	Rele, mini 1-pol 24V 16A, Schrack RT314024, Finder 4061.9024	03410026
BK64, BK65, K3, K5, K7, K13..K15, K15A, K16, K17, K19, K40	Rele, mini 2-pol 24V 10A, Schrack RT424024, Finder 4462.9024	03410027
b22	Hovedbryter, f. el.motor	03410043
F8, F9	Glassikring, 1A	03410047
K4, K8, K20	Rele, SCHRACK ZG 400024	03410065
T7, T14	Elektronisk-tidsmodul, MRMZ0W00 0, 1s-10h	03410068
K6, K24	Rele, mini 2-polet, RT424018 Schrack	03410069
K26	Sikkerheds enhet, 10°	03410070
E18	Induktiv føler, EI 1204PPCSS	03410072
AK50..AK63, BK50..BK63	Rele, RPT 2F 024	03410506
K10, K10A, K11, K11A, K21	Rele Schrack, RT31L018	03410507
LV1	Niveleringspendul, 2x1° + 2x10°	03410601
K39, K39A	Moment selector	03410606
A.X20	A.X20 Print "Outrigger link"	03410607
B.X21	B.X21 Print "Outrigger link"	03410608
G1	Ladelikeretter, 50A	03420005
Y1	Overspenningsbeskyttelse, 250V	03420009
e1	Termobryter, 63C	03420011

Dia No : 04015402

Tegnet af : MSG

Godkendt af : JJ REGSTRUP INST

Dato : 11-01-00

Revision :

Side: 12

af 15

DELELISTE

Maskin type : DL21 RBW NORSK

Maskin nr : 11131

Ekstra udstyr : EL-BETJENT UNDERVOGN, PRIORITERING, 3
HØJDER

Denka Lift A/S
Højvang 5
DK-4300 Holbæk
e-mail: INFO@DENKA.dk
Tel. +45 59 45 55 00
Fax. +45 59 44 21 55

Navn	Benevnelse	Varenr.
X4	Ladeinntak, CEE 16A F0+J	03420018
T1	Transformator, 230-260/24V 30A	03420085
X6	Klæmmestik stikdel 45 SMSTB 2, 3/14	03420112
P1	Stikkontakt	03420505
S2, S4..S20	Kontaktelement, ZB2-BE101 SL.	03430003
Q1, Q2, Q5, Q7, Q14, Q15	Kontaktelement, ZB2-BE102 BR.	03430004
S1	Kontaktelement, ZB2-BE201 SL.	03430005
b16, b19, b21, b24, b29	Vribryter, ZB2-BD2 FST.	03430010
b20	Vribryter, ZB2-BD4 2 still.ret.0	03430011
b1, b5, b9	Vribryter, ZB2-BD5 3 pos. ret.0	03430012
b13, b25	Hovednøkkel, ZB2-BG2 2still.	03430013
b14, b15	Nødstopphode, ZB2-BS844	03430078
b28	Nøkkelhoved, 3 still. 800EP-KM3R3 S+S	03430105
b23	Trykknap, ZB2-BP2 svart	03430500
b7, b18	Vribryter, ZB2-BD3 3 still. faste	03430501
X22	Klemme, PA f. 4mm ² DIN 35	03440009
X8	Klemme, PA f. 16mm ² DIN 35	03440011
X1, X21	Klemme, AKZ f. 4mm ² DIN 15	03440014
X9	Klemme, 2,5mm ²	03440017
X3	Jordklemme, PA66116	03440044
X14, X23	Klemme, 4/35 dobbelt	03440052
W21	Kabel, PVC YCL-OZ 3x0,75	03450000
W1, W3	Flat kabel, 7x1,5+21x0,75	03450003
W6	Kabel, PUR 25x0,75	03450010

Dia No : 04015402

Tegnet af : MSG

Godkendt af : JJ REGISTRUP INST

Dato : 11-01-00

Revision :

Side: 13

af 15

DELELISTE

Maskin type : DL21 RBW NORSK

Maskin nr : 11131

Ekstra udstyr : EL-BETJENT UNDERVOGN, PRIORITERING, 3
HØJDER

Denka Lift A/S
Højvang 5
DK-4300 Holbæk
e-mail: INFO@DENKA.dk
Tel. +45 59 45 55 00
Fax. +45 59 44 21 55

Navn	Benevnelse	Varenr.
W7	Kabel, PVC YCL-OZ 4x0,75	03450016
W2	Kabel, SVART PKAJ 4x1,5	03450045
W24	Kabel, 12x0,75 OZ	03450091
SR1	Slepering, 2701 f. krøjekontakt 220V	03460001
SR1	Slepering, 2702 f. krøjekontakt 24V	03460002
S31..S36	Retningskontakt dobbeltvirkende m/potmeterfeste	03470020
P11, P12	Kamskive, CS0 61A	03470026
b10	Manøverspak 4-vejs u. kulisse S&B	03470036
R31 R32, R33 R34	Potentiometer, 21/50 2x30#	03470042
b8 b6, b12 b11	Joystikk, 2-vejs, XD2-PA22	03470051
b3 b4 b25 b26	Joystikk, 4-vejs, XD2-PA24	03470052
b10	Sluttekontakt kpl. f. S&B	03470065
H2, H7	Lysdiode, grøn 5mm	03480002
H1	Lysdiode, gul 5mm	03480003
X10	Multistikklemme, BL 13 12602-6	03480018
K, L, U2	Multistikklemme, BL 14 12603-6	03480019
U1, U3, X12, X20, X21	Multistikklemme, BL 15 12604-6	03480020
H3	Lysdiode, rød blink	03480027
J5	Jumper, ZTMJB-401	03480036
X7	Multistikklemme, BL 9	03480070
Side 6	Printkort, 15-18/20	03480083
D8..D66, D68..D73, D90, D91, D93, D96..D99, D101..D119	Halvlederdiode, 1n4007 1000V	03480101
D3..D7	Diode, 3 Amp. 400V	03480103
D1, D2	Diode, 6 Amp. 400V	03480104

Dia No : 04015402

Tegnet af : MSG

Godkendt af : JJ REGISTRUP INST

Dato : 11-01-00

Revision :

Side: 14

af 15

