

DENKA LIFT Højvang 5 4300 Holbæk Phone 59 45 55 00	Lift type : DL16/18 RBW NORSK	No : 10988	Hydraulics : Atos On/Off Ver.2	Dia. No. : 04015310
	Extra equipment: EL-BETJENT UNDERVOGN, SELVKJØRING PÅ KURV	Drawn by : MSG	Approved by : JJ REGSTRUP INST	Date : 25-08-99 Rev. :
				Title : Nøgleskema
				Page : 1 of 15

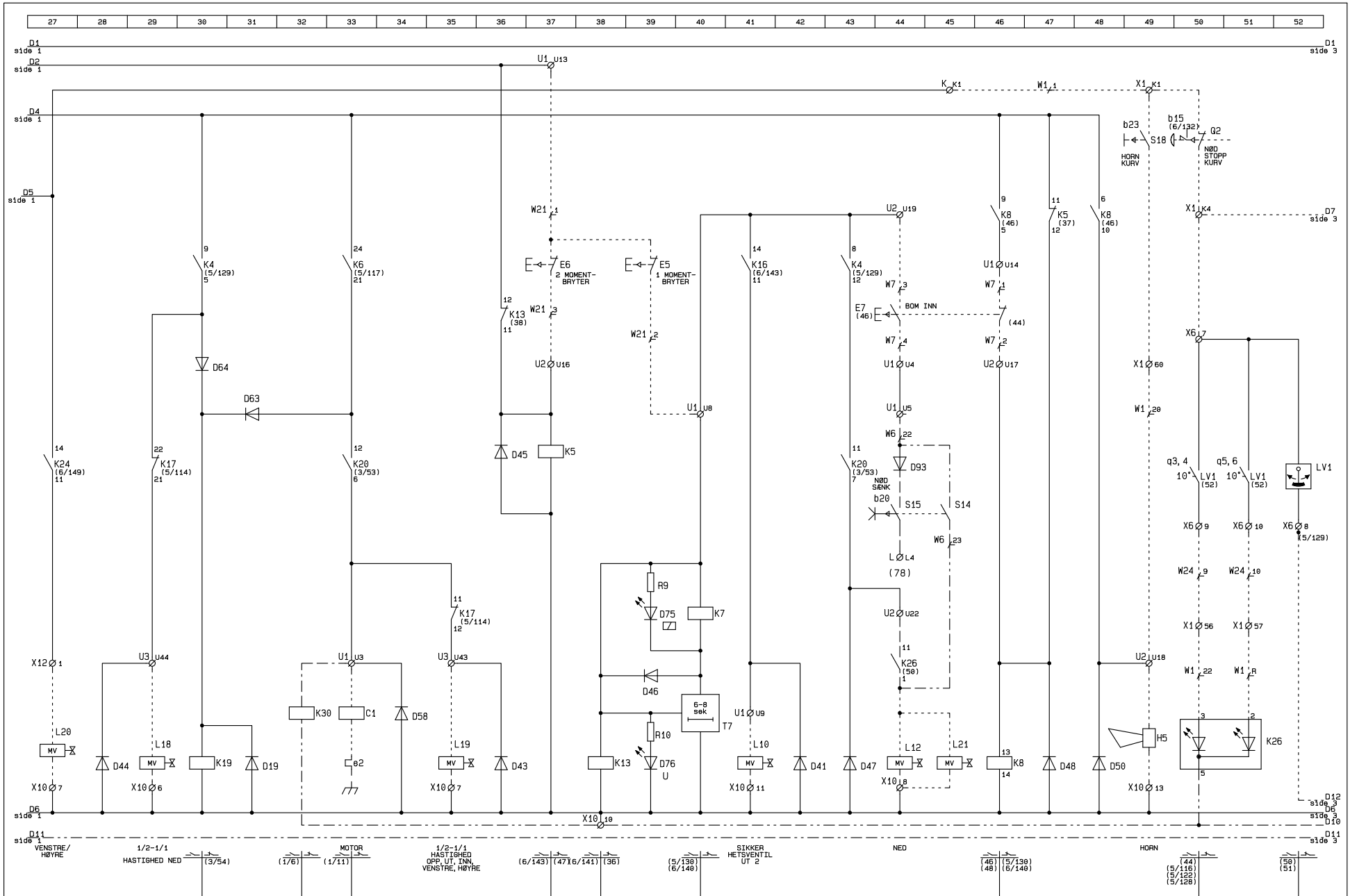

DENKA LIFT Højvang 5 4300 Holbæk Phone 59 45 55 00	Lift type : DL16/18 RBW NORSK Extra equipment: EL-BETJENT UNDERVOGN, SELVKJØRING PÅ KURV Drawn by : MSG	No : 10988 Hydraulics : Atos On/Off Ver.2 Approved by : JJ REGISTRUP INST	Dia. No. : 04015310 Title : Nøgleskema Page : 2 of 15
Date : 25-08-99 Rev. :		Date : 25-08-99 Rev. :	

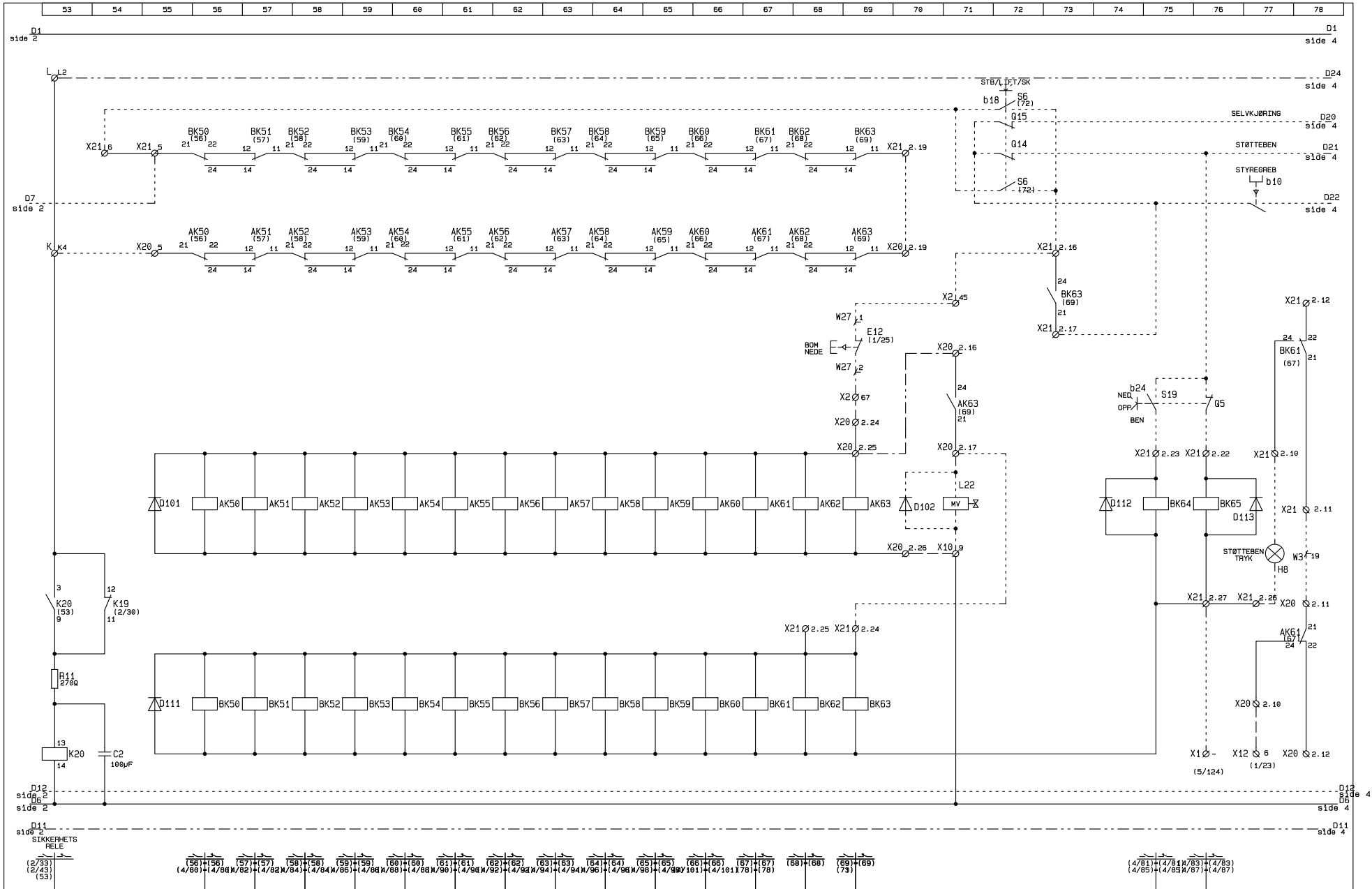

<h1>DENKA LIFT</h1>	Lift type : DL16/18 RBW NORSK	No : 10988	Hydraulics : Atos On/Off Ver.2	Dia. No. : 04015310
	Extra equipment: EL-BETJENT UNDERVOGN, SELVKJØRING PÅ KURV	Drawn by : MSG	Approved by : JJ REGSTRUP INST	Title : Nøgleskema
Højvang 5 4300 Holbæk Phone 59 45 55 00			Date : 25-08-99 Rev. :	Page : 3 of 15

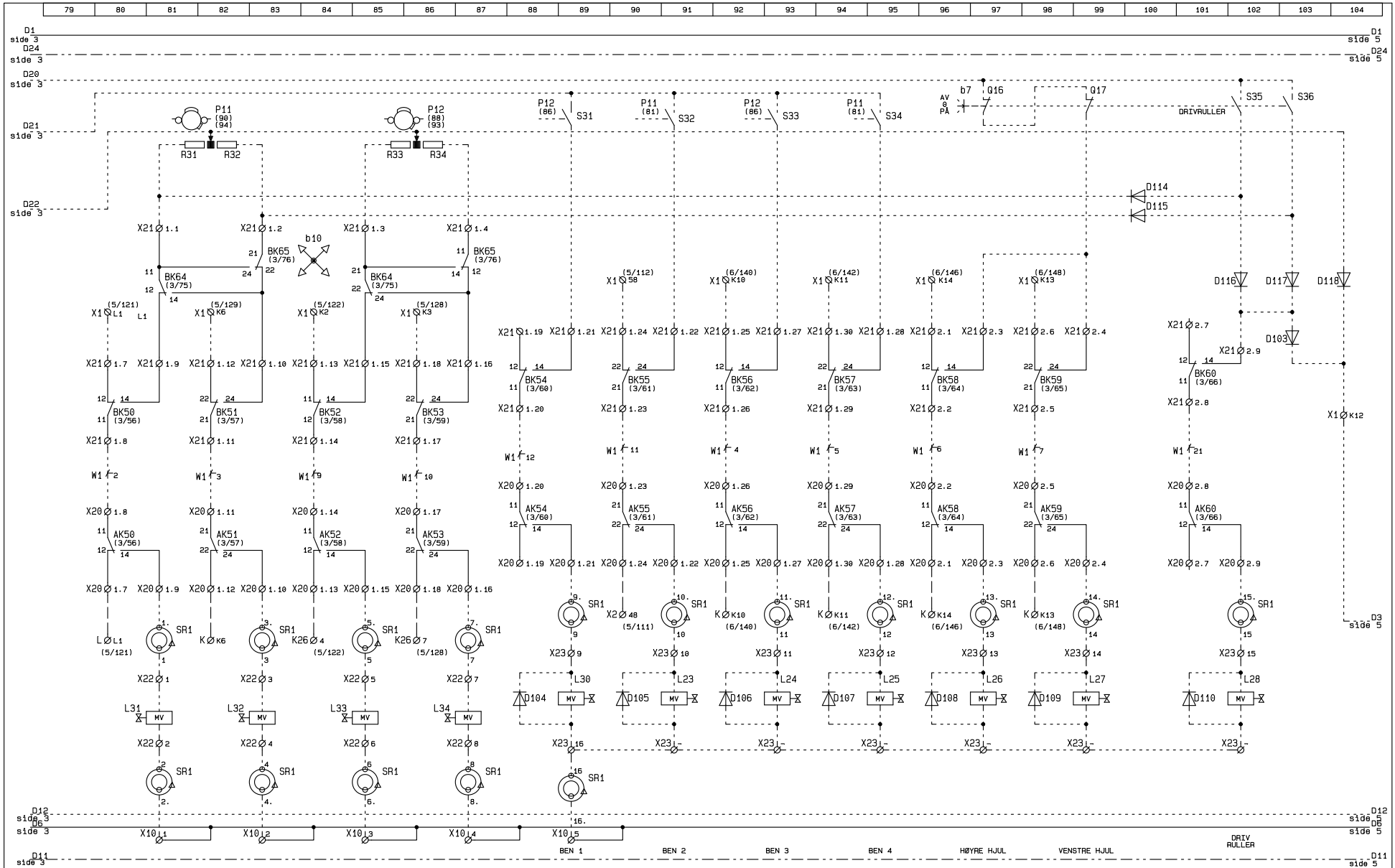

DENKA LIFT

Lift type : DL16/18 RBW NORSK

No : 10988

Hydraulics : Atos On/Off Ver.2

Dia. No. : 04015310

Extra equipment: EL-BETJENT UNDERVOGN, SELVKJØRING PÅ KURV

Title : Nøgleskema

Højvang 5 4300 Holbæk Phone 59 45 55 00

Drawn by : MSG

Approved by : JJ REGSTRUP INST

Date : 25-08-99 Rev. :

Page : 4 of 15

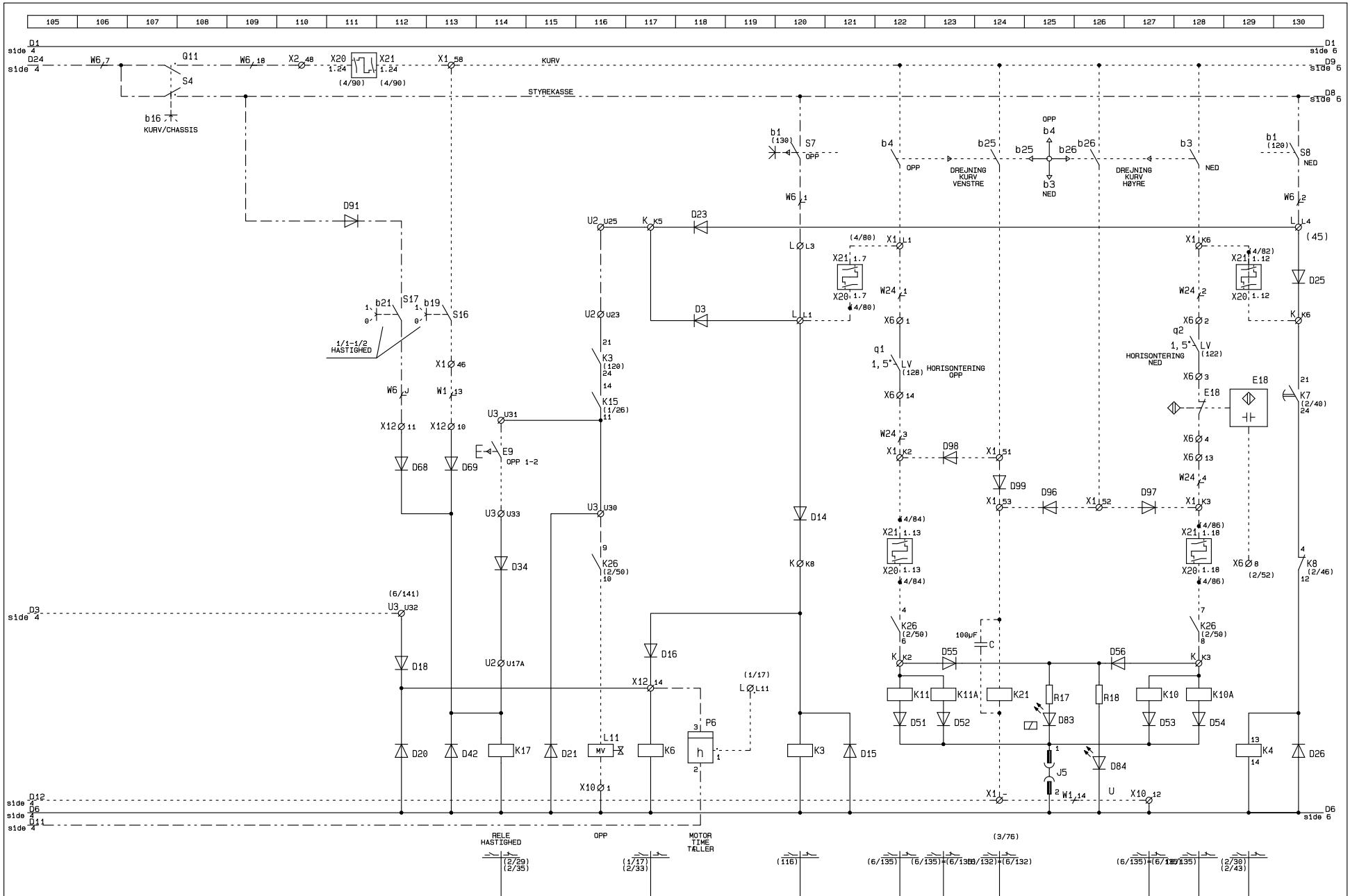

DENKA LIFT Højvang 5 4300 Holbæk Phone 59 45 55 00	Lift type : DL16/18 RBW NORSK	No : 10988	Hydraulics : Atos On/Off Ver.2	Dia. No. : 04015310
	Extra equipment: EL-BETJENT UNDERVOGN, SELVKJØRING PÅ KURV	Drawn by : MSG	Approved by : JJ REGSTRUP INST	Title : Nøgleskema
			Date : 25-08-99 Rev. :	Page : 5 of 15

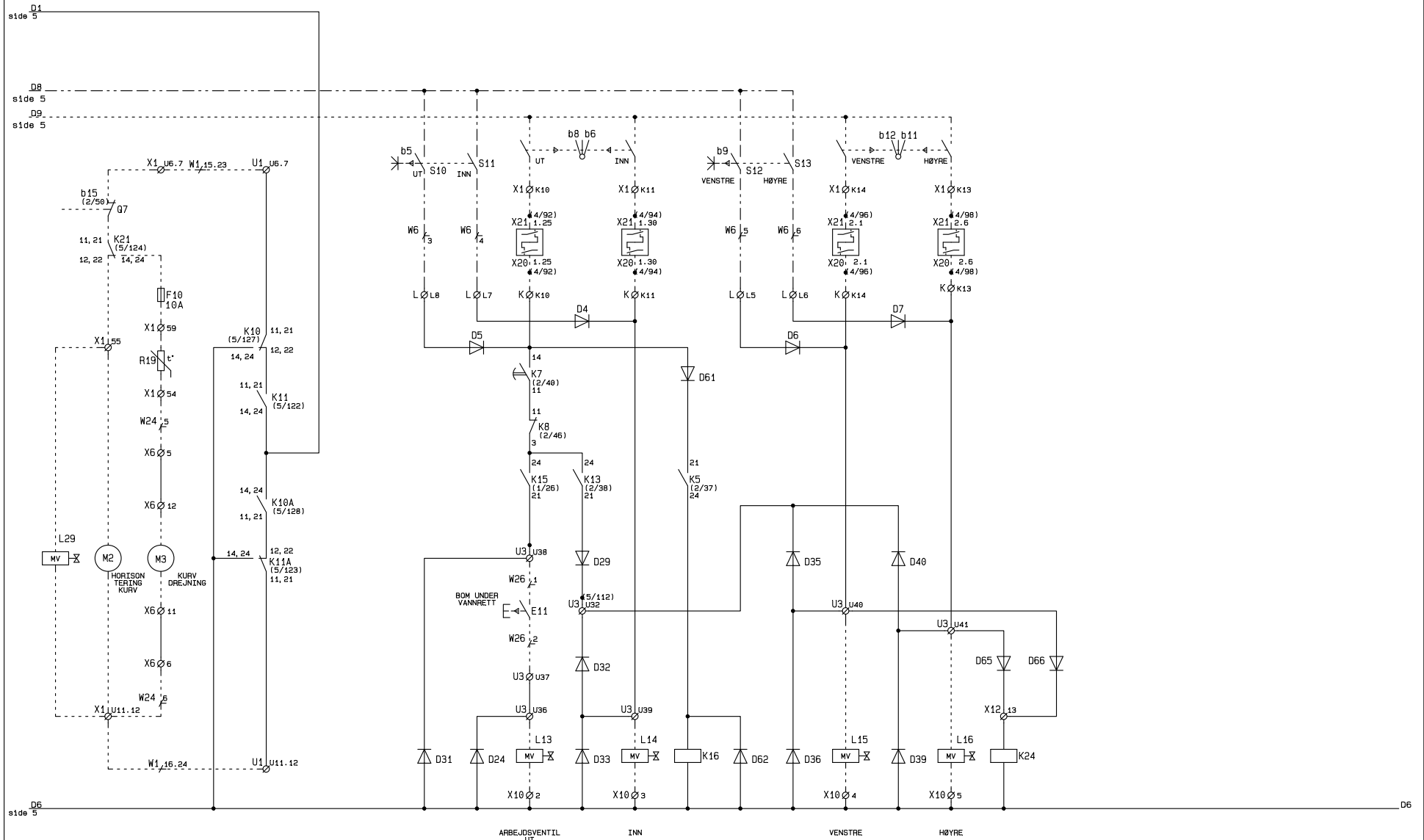

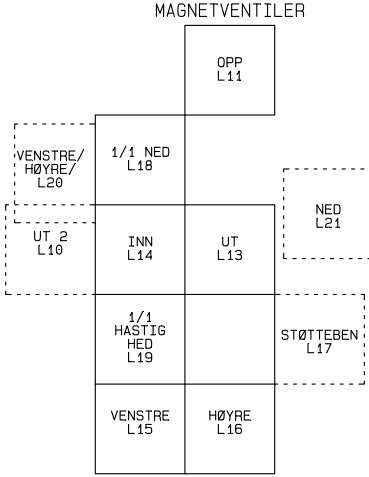
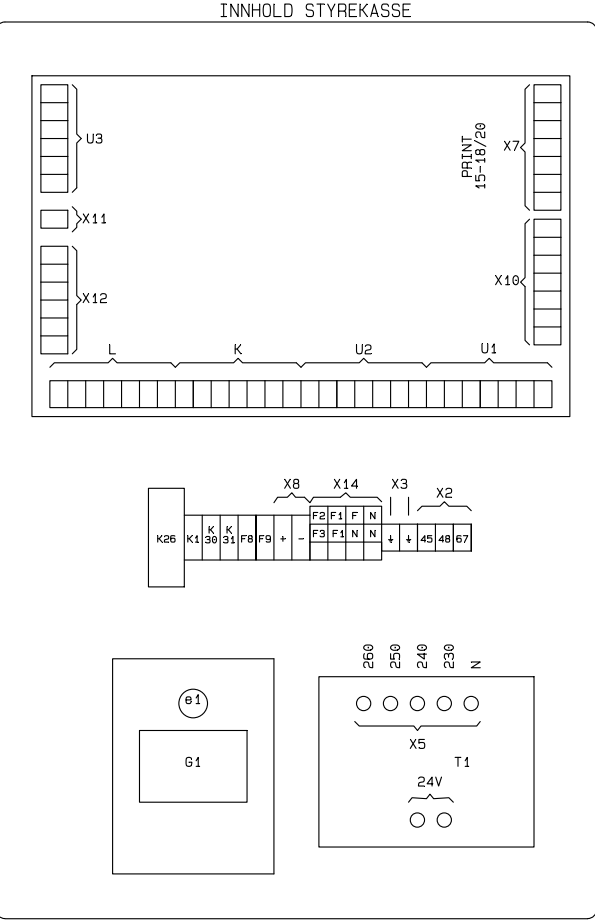
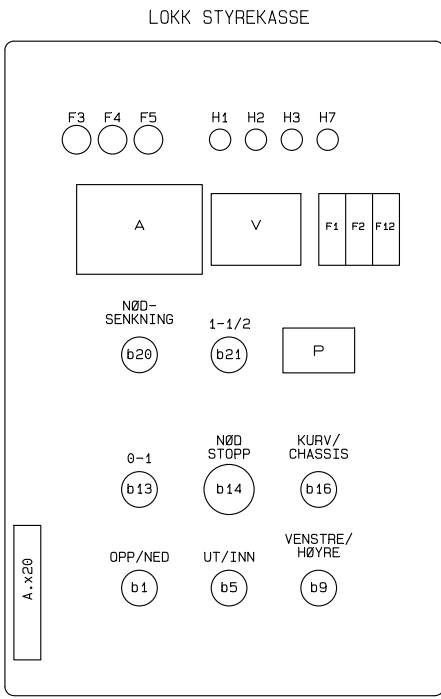
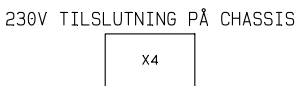
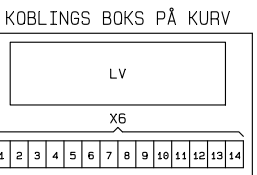
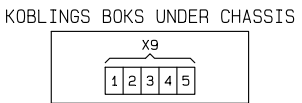
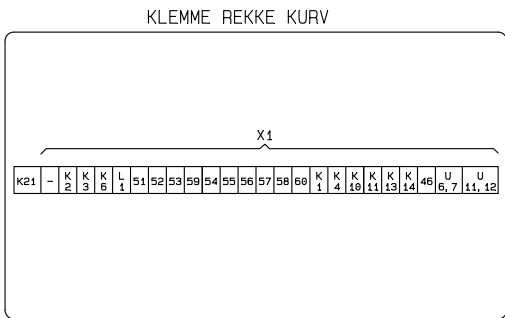
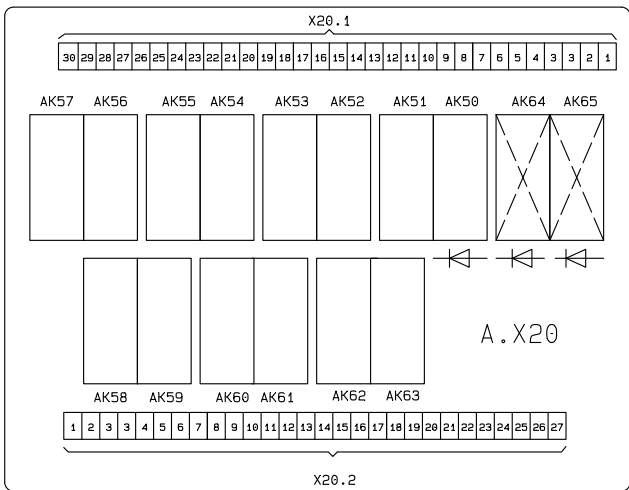
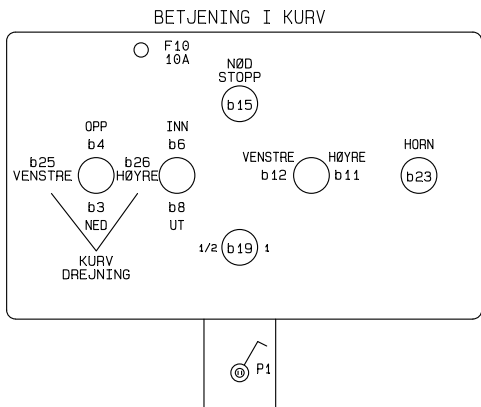

— PRINT
 - - - - - STYREKASSE
 - - - - - UT STYREKASSE

KOBLINGS BOKS CHASSIS

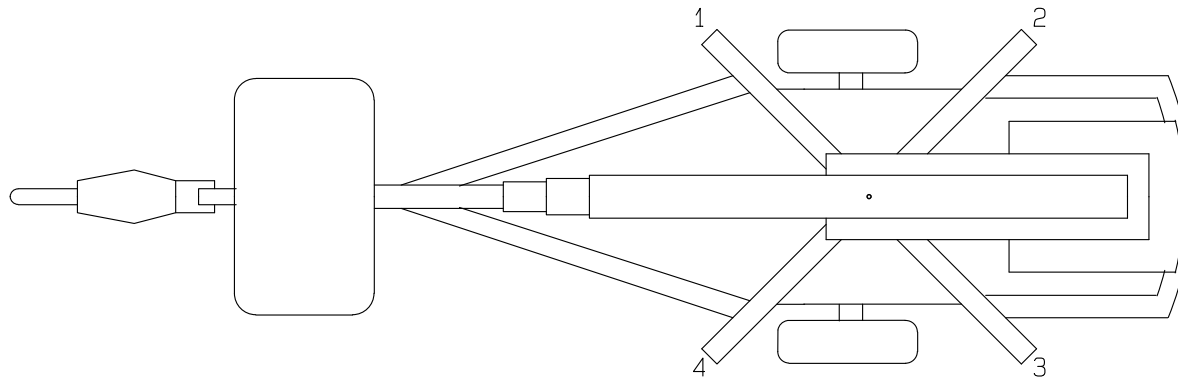
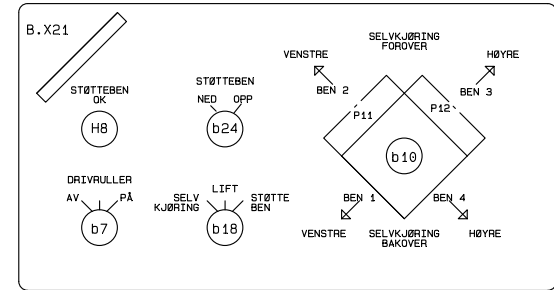
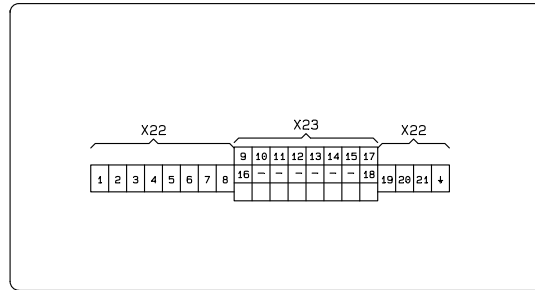
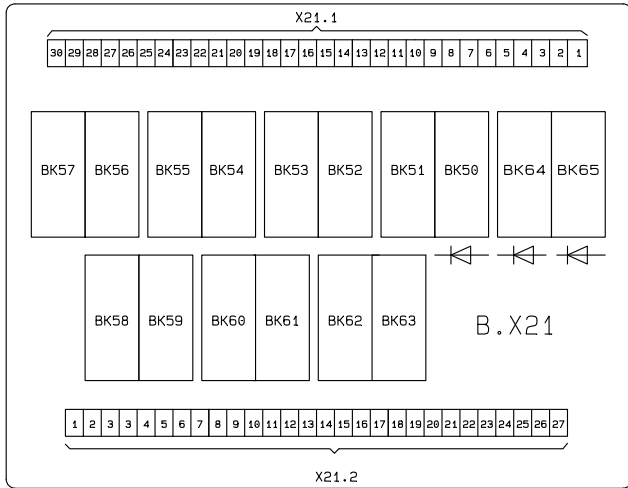

L34		BEN 3	SELV KJÖRING HÖYRE	BEN 1	FRI
	L24	L26	L22		
L33					

L32		BEN 4	SELV KJÖRING VENSTRE	BEN 2	DRIV RULLER
	L25	L27	L23	L28	
L31					

- 2 SIDELYS
- 3 HØYRE/VENSTRE BLINK
- 4 HØYRE/VENSTRE BAKLYS
- 5 STOPP
- 6 SKILTLYS
- 7 TÅGEBAGLYS
- LEDNINGSNUMMERE

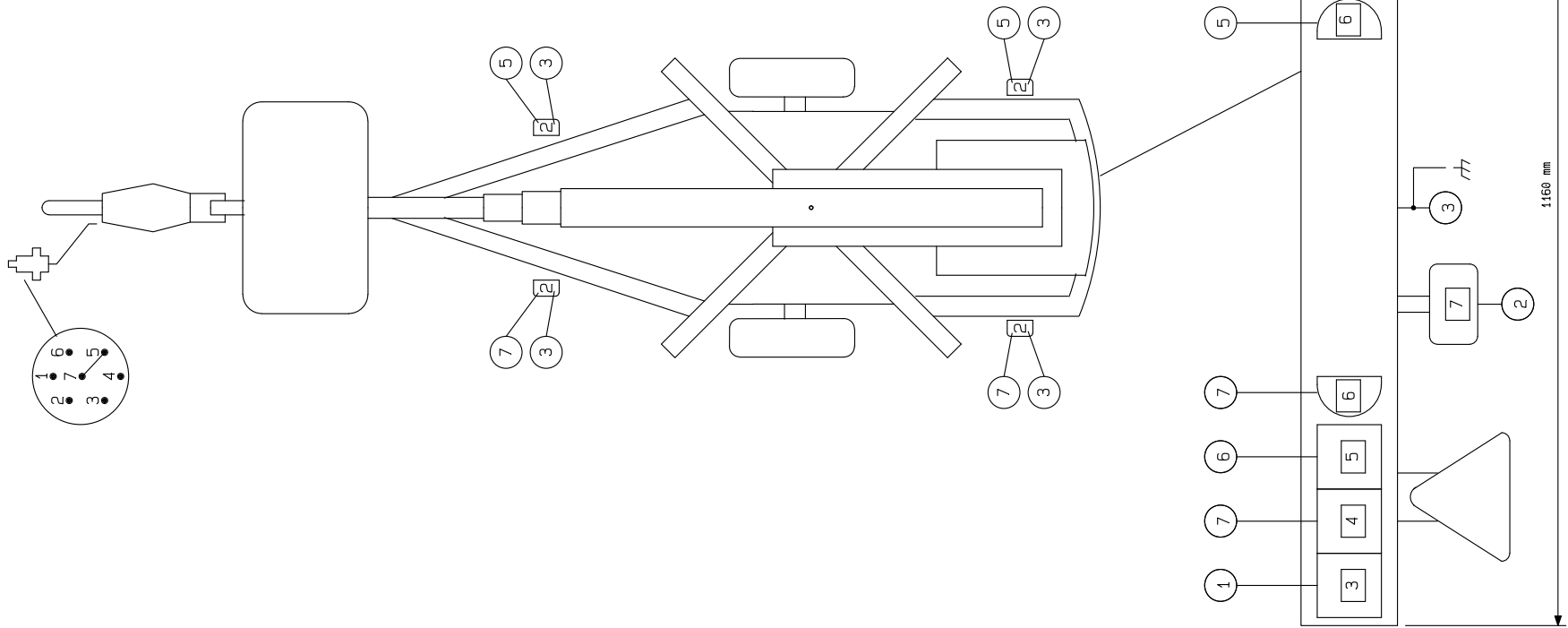

DENKA LIFT

Lift type : DL16/18 RBW NORSK

No : 10988

Hydraulics : Atos On/Off Ver.2

Dia. No. : 04015310

Extra equipment: EL-BETJENT UNDERVOGN, SELVKJØRING PÅ KURV

Title : Lyspanel

Højvang 5 4300 Holbæk Phone 59 45 55 00

Drawn by : MSG

Approved by : JJ REGSTRUP INST

Date : 25-08-99 Rev. :

Page : 10 of 15

DELELISTE

Maskin type : DL16/18 RBW NORSK

Maskin nr : 10988

Ekstra udstyr : EL-BETJENT UNDERVOGN, SELVKJØRING PÅ KURV

Denka Lift A/S
Højvang 5
DK-4300 Holbæk
e-mail: INFO@DENKA.dk
Tel. +45 59 45 55 00
Fax. +45 59 44 21 55

Navn	Benevnelse	Varenr.
H5	Horn, 24V	03080016
E5, E6	Endestopp, XCK-J561	03090003
E7	Endestopp, XCK-M521	03090013
E9	Endestopp, XCK-S141	03090023
E11	Endestopp, XCK-S541	03090033
E12		03090070
E20..E23	Endestopp, XCK-P502	03090101
L10, L18..L30	Spole, CCS0 24D	03240005
L11, L13..L16	Magnetspole, DHI 24V DC	03240021
L12	Spole, LISK 36W 24V	03240034
L31..L34	Magnetspole, SP-60Z0A-1-1-00/24DC	03240082
M1	El.motor, 24MC 42 THWA	03300004
e2	Termobryter, 755 KTS f. Hesselman	03300017
M2	El.motor, kpl. Pavalux	03300029
C1	Startrele, 0333 006 006	03300052
M3	Motordel, 30-24V DC	03360011
B1..B4	Batteri 24015 6V	03390004
V	Voltmeter, KM 48	03400001
A	Amperemeter, GB R59M 0/50A	03400007
P6	Timetæller, Digital 48x24 TY.1 12-24 VDC	03400020
F4, F5	Glassikring, 4A	03410005
F10	Glassikring, 10A	03410006
F3	Glassikring, 16A	03410007

Dia No : 04015310

Tegnet af : MSG

Godkendt af : JJ REGISTRUP INST

Dato : 25-08-99

Revision :

Side: 11

af 15

DELELISTE

Maskin type : DL16/18 RBW NORSK

Maskin nr : 10988

Ekstra udstyr : EL-BETJENT UNDERVOGN, SELVKJØRING PÅ KURV

Denka Lift A/S
Højvang 5
DK-4300 Holbæk
e-mail: INFO@DENKA.dk
Tel. +45 59 45 55 00
Fax. +45 59 44 21 55

Navn	Benevnelse	Varenr.
F11	Sikring, 125A Din 00	03410008
F1, F12	Automatsikring, 10A	03410009
F2	Automatsikring, 50A	03410010
K2	Rele, dobbelt 19/29V	03410020
K1, K30, K31	Rele, mini 1-pol 24V 16A, Schrack RT314024, Finder 4061.9024	03410026
BK64, BK65, K3, K5, K7, K13..K15, K15A, K16, K17, K19	Rele, mini 2-pol 24V 10A, Schrack RT424024, Finder 4462.9024	03410027
b22	Hovedbryter, f. el.motor	03410043
F8, F9	Glassikring, 1A	03410047
K4, K8, K20	Rele, SCHRACK ZG 400024	03410065
T7, T14	Elektronisk-tidsmodul, MRMZ0W00 0, 1s-10h	03410068
K6, K24	Rele, mini 2-polet, RT424018 Schrack	03410069
K26	Sikkerhets enhet, 10°	03410070
E18	Induktiv føler, EI 1204PPCSS	03410072
AK50..AK63, BK50..BK63	Rele, RPT 2F 024	03410506
K10, K10A, K11, K11A, K21	Rele Schrack, RT31L018	03410507
LV1	Niveleringspendul, 2x1° + 2x10°	03410601
A.X20	A.X20 Print "Outrigger link"	03410607
B.X21	B.X21 Print "Outrigger link"	03410608
G1	Ladelikeretter, 50A	03420005
Y1	Overspenningsbeskyttelse, 250V	03420009
e1	Termobryter, 63C	03420011
X4	Ladeinntak, CEE 16A F0+J	03420018
T1	Transformator, 230-260/24V 30A	03420085
X6	Klemmestik stikdel 45 SMSTB 2,3/14	03420112

Dia No : 04015310

Tegnet af : MSG

Godkendt af : JJ REGSTRUP INST

Dato : 25-08-99

Revision :

Side: 12

af 15

DELELISTE

Maskin type : DL16/18 RBW NORSK

Maskin nr : 10988

Ekstra udstyr : EL-BETJENT UNDERVOGN, SELVKJØRING PÅ KURV

Denka Lift A/S
Højvang 5
DK-4300 Holbæk
e-mail: INFO@DENKA.dk
Tel. +45 59 45 55 00
Fax. +45 59 44 21 55

Navn	Benevnelse	Varenr.
P1	Stikkontakt	03420505
S2, S4, S6..S19	Kontaktelement, ZB2-BE101 SL.	03430003
Q1, Q2, Q5, Q7, Q11, Q14..Q17	Kontaktelement, ZB2-BE102 BR.	03430004
S1	Kontaktelement, ZB2-BE201 SL.	03430005
b16, b19, b21, b24	Vribryter, ZB2-BD2 FST.	03430010
b20	Vribryter, ZB2-BD4 2 still.ret.0	03430011
b1, b5, b7, b9	Vribryter, ZB2-BD5 3 pos. ret.0	03430012
b13	Hovednøkkel, ZB2-BG2 2still.	03430013
b14, b15	Nødstopphode, ZB2-BS844	03430078
b23	Trykkknop, ZB2-BP2 svart	03430500
b18	Vribryter, ZB2-BD3 3 still. faste	03430501
X2, X22	Klemme, PA f. 4mm ² DIN 35	03440009
X8	Klemme, PA f. 16mm ² DIN 35	03440011
X1, X21	Klemme, AKZ f. 4mm ² DIN 15	03440014
X9	Klemme, 2,5mm ²	03440017
X3	Jordklemme, PA66116	03440044
X14, X23	Klemme, 4/35 dobbelt	03440052
W21	Kabel, PVC YCL-OZ 3x0,75	03450000
W1, W3	Flat kabel, 7x1,5+21x0,75	03450003
W6	Kabel, PUR 25x0,75	03450010
W7, W26, W27	Kabel, PVC YCL-OZ 4x0,75	03450016
W2	Kabel, SVART PKAJ 4x1,5	03450045
W24	Kabel, 12x0,75 OZ	03450091
SR1	Slepering, 2701 f. krøjekontakt 220V	03460001

Dia No : 04015310

Tegnet af : MSG

Godkendt af : JJ REGSTRUP INST

Dato : 25-08-99

Revision :

Side: 13

af 15

DELELISTE

Maskin type : DL16/18 RBW NORSK

Maskin nr : 10988

Ekstra udstyr : EL-BETJENT UNDERVOGN, SELVKJØRING PÅ KURV

Denka Lift A/S
Højvang 5
DK-4300 Holbæk
e-mail: INFO@DENKA.dk
Tel. +45 59 45 55 00
Fax. +45 59 44 21 55

Navn	Benevnelse	Varenr.
SR1	Slepering, 2702 f. krøjekontakt 24V	03460002
S31..S36	Retningskontakt dobbeltvirkende m/potmeterfeste	03470020
b25	Manøverspak 4-vejs VRZ-254-6 opp/ned m/retningsk.+svingb.kur	03470025
P11, P12	Kamskive, CS0 61A	03470026
R31 R32, R33 R34	Potentiometer, 21/50 2x30#	03470042
b8 b6, b12 b11	Joystikk, 2-vejs, XD2-PA22	03470051
b3 b4 b25 b26	Joystikk, 4-vejs, XD2-PA24	03470052
b10	Sluttekontakt kpl. f. S&B	03470065
H3	Lysdiode, rød 5mm	03480001
H2, H7	Lysdiode, grøn 5mm	03480002
H1	Lysdiode, gul 5mm	03480003
X10	Multistikklemme, BL 13 12602-6	03480018
K, L, U2	Multistikklemme, BL 14 12603-6	03480019
U1, U3, X12, X20, X21	Multistikklemme, BL 15 12604-6	03480020
J5	Jumper, ZTMJB-401	03480036
X7	Multistikklemme, BL 9	03480070
Side 6	Printkort, 15-18/20	03480083
D8..D66, D68..D73, D90, D91, D93, D96..D99, D101..D118	Halvlederdiode, 1n4007 1000V	03480101
D3..D7	Diode, 3 Amp. 400V	03480103
D1, D2	Diode, 6 Amp. 400V	03480104
D76, D80, D84	Lysdiode, grøn 5mm	03480106
D75, D79, D83	Lysdiode, gul 5mm	03480107
C, C2	Kondensator, 100µF 63V	03480150
C3	Kondensator, 0,22µF x1 300V SH	03480151

Dia No : 04015310

Tegnet af : MSG

Godkendt af : JJ REGISTRUP INST

Dato : 25-08-99

Revision :

Side: 14

af 15

